

- **Low Quiescent Supply Current of 20 μ A**
- **Optimized for Low-Power/Battery-Operated Applications**
- **Two Input Control Lines for Reduced Microcontroller Overhead**
- **Internal Current Shutdown of 5 A**
- **40 V Load Dump Rating**
- **Integrated Fault Protection and Diagnostics**
- **CMOS Compatible Schmitt Trigger Inputs for High Noise Immunity**

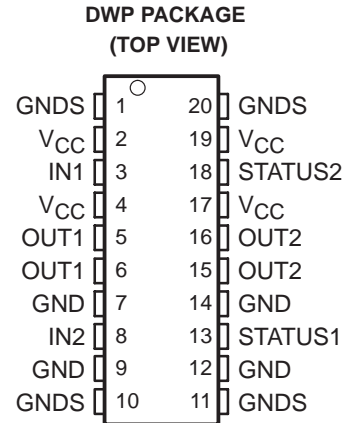

description

The TPIC0108B is a PWM control intelligent H-bridge designed specifically for dc motor applications. The device provides forward, reverse, and brake modes of operation. A logic supply voltage of 5 V is internally derived from V_{CC}.

The TPIC0108B has an extremely low r_{DS(on)}, 280 m Ω typical, to minimize system power dissipation. The control inputs (IN1 and IN2) greatly simplify the microcontroller overhead requirement. The device has a low quiescent supply current of 20 μ A to suit a wide range of automotive and industrial battery-operated applications.

The TPIC0108B provides protection against over-voltage, over-current, over-temperature, and cross conduction faults. Fault diagnostics can be obtained by monitoring the STATUS1 and STATUS2 terminals and the two input control lines. STATUS1 is an open-drain output suitable for wired-or connection. STATUS2 is a push-pull output that provides a latched status output. Under-voltage protection ensures that the outputs, OUT1 and OUT2, will be disabled when V_{CC} is less than the under-voltage detection voltage V_(UVCC).

The TPIC0108B is designed using TI's LinBiCMOS™ process. LinBiCMOS allows the integration of low power CMOS structures, precision bipolar cells, and low impedance DMOS transistors.

The TPIC0108B is offered in a 20-pin thermally enhanced small-outline package (DWP) and is characterized for operation over the operating case temperature of –40°C to 125°C.

FUNCTION TABLE

IN1	IN2	OUT1	OUT2	MODE
0	0	Z	Z	Quiescent supply current mode
0	1	LS	HS	Motor turns clockwise
1	0	HS	LS	Motor turns counter clockwise
1	1	HS	HS	Brake, both HSDs turned on hard



Please be aware that an important notice concerning availability, standard warranty, and use in critical applications of Texas Instruments semiconductor products and disclaimers thereto appears at the end of this data sheet.

LinBiCMOS is a trademark of Texas Instruments Incorporated.

PRODUCTION DATA information is current as of publication date. Products conform to specifications per the terms of Texas Instruments standard warranty. Production processing does not necessarily include testing of all parameters.



POST OFFICE BOX 655303 • DALLAS, TEXAS 75265

Copyright © 2002, Texas Instruments Incorporated

TPIC0108B PWM CONTROL INTELLIGENT H-BRIDGE

SLIS068A – NOVEMBER1998 – REVISED APRIL 2002

block schematic

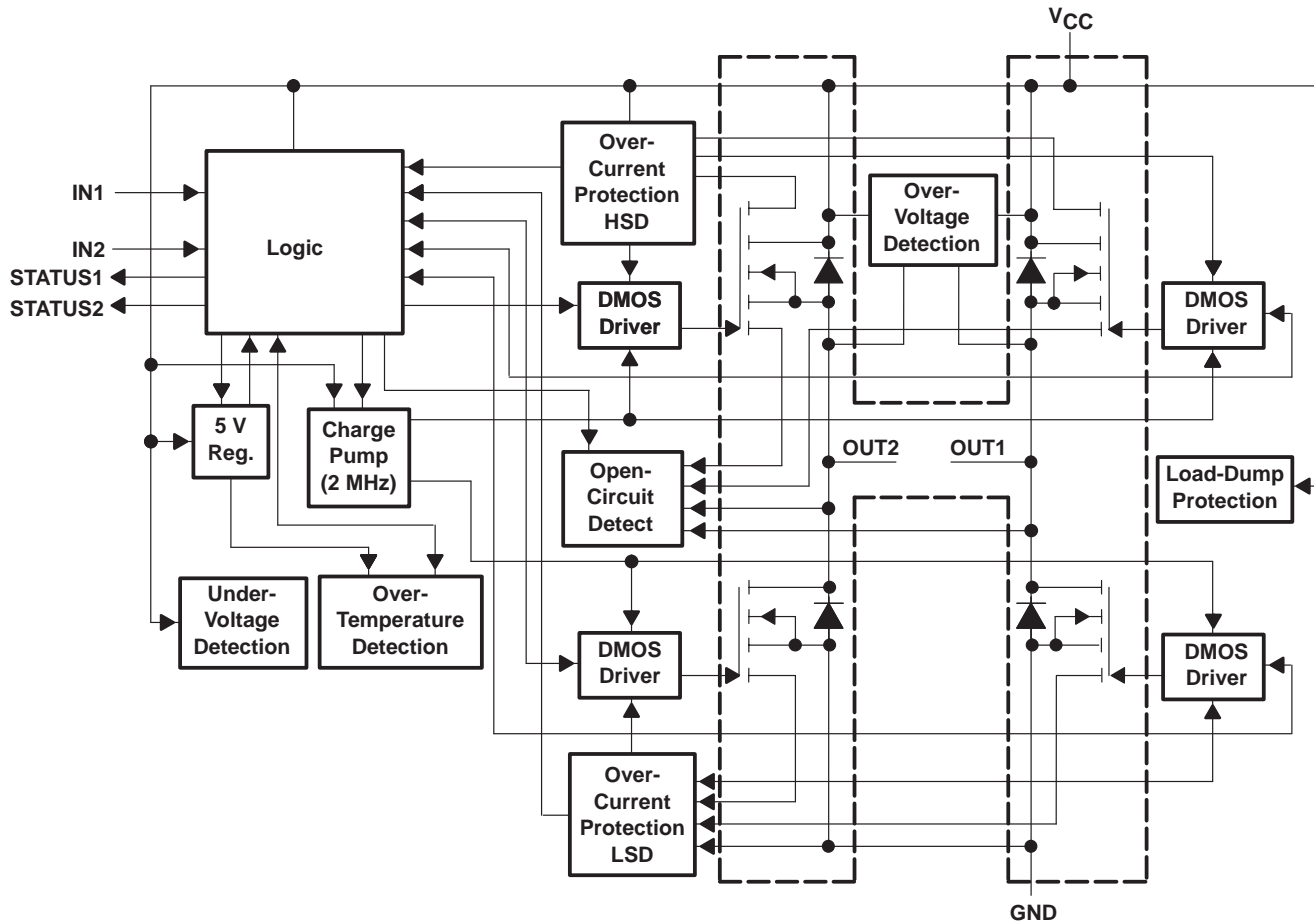

Terminal Functions

TERMINAL NAME	NO.	I/O	DESCRIPTION
GND	7, 9, 12, 14	I	Power ground
GNDS	1, 10, 11, 20	I	Substrate ground
IN1	3	I	Control input
IN2	8	I	Control input
OUT1	5, 6	O	Half-H output. DMOS output
OUT2	15, 16	O	Half-H output. DMOS output
STATUS1	13	O	Status output
STATUS2	18	O	Latched status output
VCC	2, 4, 17, 19	I	Supply voltage

NOTE: It is mandatory that all four ground terminals plus at least one substrate terminal are connected to the system ground. Use all VCC and OUT terminals.

schematics of inputs and outputs

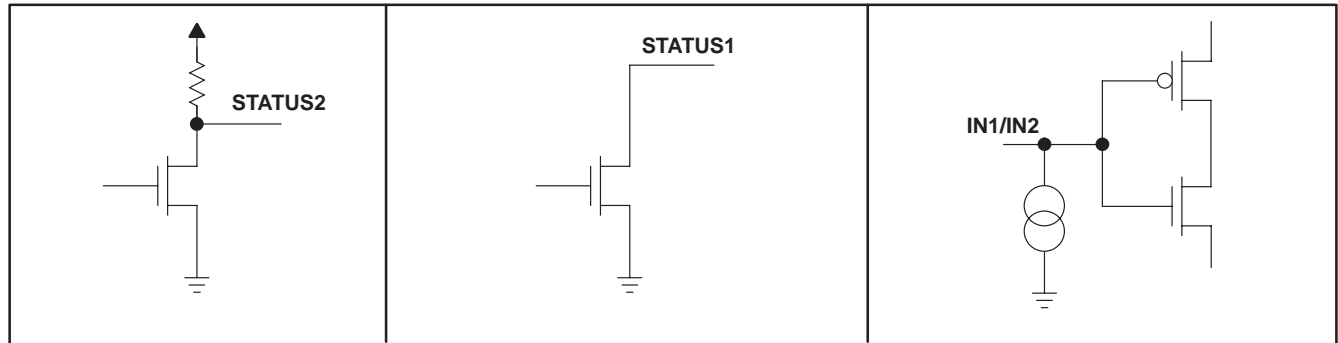

absolute maximum ratings over operating case temperature range (unless otherwise noted)†

Power supply voltage range, V_{CC}	-0.3 V to 33 V
Logic input voltage range, V_{IN}	-0.3 V to 7 V
Load dump (for 400 ms; $T_C = 25^\circ\text{C}$)	40 V
Status output voltage range, $V_{O(\text{status})}$	-0.3 V to 7 V
Continuous power dissipation, $T_C = 25^\circ\text{C}$	1.29 W
Storage temperature range, T_{stg}	-55°C to 150°C
Maximum junction temperature, T_J	150°C

† Stresses beyond those listed under “absolute maximum ratings” may cause permanent damage to the device. These are stress ratings only, and functional operation of the device at these or any other conditions beyond those indicated under “recommended operating conditions” is not implied. Exposure to absolute-maximum-rated conditions for extended periods may affect device reliability.

DISSIPATION RATING TABLE

$T_A \leq 25^\circ\text{C}$	DERATING FACTOR	$T_A = 70^\circ\text{C}$	$T_A = 125^\circ\text{C}$
POWER RATING	ABOVE $T_A = 25^\circ\text{C}$	POWER RATING	POWER RATING
1.29 W	0.0104 W/°C	0.82 W	0.25 W

recommended operating conditions

	MIN	MAX	UNIT
Supply voltage, V_{CC}	6	18	V
Operating case temperature, T_C	-40	125	°C
Switching frequency, f_{PWM}		2	kHz

TPIC0108B

PWM CONTROL INTELLIGENT H-BRIDGE

SLIS068A – NOVEMBER1998 – REVISED APRIL 2002

electrical characteristics over recommended operating case temperature range and $V_{CC} = 5\text{ V}$ to 6 V (unless otherwise noted)

PARAMETER		TEST CONDITIONS	MIN	TYP	MAX	UNIT
$r_{DS(on)}$	Static drain-source on-resistance (per transistor) $I_{(BR)} = 1\text{ A}$	LSD	$T_J = 25^\circ\text{C}$		550	m Ω
			$T_J = 150^\circ\text{C}$		850	
		HSD	$T_J = 25^\circ\text{C}$		600	m Ω
			$T_J = 150^\circ\text{C}$		870	
$I_{(QCD)}$	Open circuit detection current		10	40	100	mA
$V_{(UVCC(OFF))}$	Under voltage detection on V_{CC} , switch off voltage	See Note 1			5	V
$V_{(UVCC(ON))}$	Under voltage detection on V_{CC} , switch on voltage	See Note 1			5.2	V
$V_{(STL)}$	STATUS low output voltage	$I_O = 100\ \mu\text{A}$, See Note 1			0.8	V
$V_{(ST2H)}$	STATUS2 high output voltage	$I_O = 20\ \mu\text{A}$, See Note 1	3		5.4	V
$I_{(ST(OFF))}$	STATUS output leakage current	$V_{(ST)} = 5\text{ V}$, See Note 1			5	μA
V_{IL}	Low level logic input voltage		-0.3		0.5	V
V_{IH}	High level logic input voltage		3.6		7	V
ΔV_I	Hysteresis of input voltage		0.3			V
I_{IH}	High level logic input current	$V_{IH} = 3.5\text{ V}$	2	10	50	μA

NOTE 1: The device functions according to the function table for V_{CC} between $V_{(UVCC)}$ and 5 V (no parameters specified). STATUS outputs are not defined for V_{CC} less than $V_{(UVCC)}$.

electrical characteristics over recommended operating case temperature and supply voltage ranges (unless otherwise noted) (see Note 2)

PARAMETER		TEST CONDITIONS		MIN	TYP	MAX	UNIT	
$r_{DS(on)}$	Static drain-source on-resistance (per transistor) $I_{BR} = 1$ A	LSD	$T_J = 25^\circ\text{C}$	$V_{CC} = 6$ V to 9 V		380	m Ω	
				$V_{CC} = 9$ V to 18 V	280	340		
			$T_J = 150^\circ\text{C}$	$V_{CC} = 6$ V to 9 V		620		
				$V_{CC} = 9$ V to 18 V	400	560		
		HSD	$T_J = 25^\circ\text{C}$	$V_{CC} = 6$ V to 9 V		430		m Ω
				$V_{CC} = 9$ V to 18 V	280	340		
			$T_J = 150^\circ\text{C}$	$V_{CC} = 6$ V to 9 V		640		
				$V_{CC} = 9$ V to 18 V	400	560		
$I_{(QB)}$	Quiescent battery current	$T_J = 25^\circ\text{C}$	$V_{CC} = 13.2$ V			20	μA	
$I_{(QCD)}$	Open circuit detection current			10	40	100	mA	
T_{SDS}	Static thermal shutdown temperature	See Notes 3 and 4		140			$^\circ\text{C}$	
T_{SDD}	Dynamic thermal shutdown temperature	See Notes 3 and 5		160			$^\circ\text{C}$	
I_{CS}	Current shutdown limit	$V_{CC} = 6$ V to 9 V		4.8		7.5	A	
		$V_{CC} = 9$ V to 18 V		5		7.5		
$I_{(CON)}$	Continuous bridge current	$T_J = 125^\circ\text{C}$, Operating lifetime 10,000 hours, (see Figure 1)				3	A	
$V_{(OVCC)}$	Over voltage detection on V_{CC}			27		36	V	
$V_{(STL)}$	STATUS low output voltage	$I_O = 100$ μA				0.8	V	
$V_{(ST2H)}$	STATUS2 high output voltage	$I_O = 20$ μA		3.9		5.4	V	
$I_{(ST(OFF))}$	STATUS output leakage current	$V_{(ST)} = 5$ V				5	μA	
V_{IL}	Low level logic input voltage			-0.3		0.8	V	
V_{IH}	High level logic input voltage			3.6		7	V	
ΔV_I	Hysteresis of input voltage			0.3			V	
I_{IH}	High level logic input current	$V_{IH} = 3.5$ V		2	10	50	μA	

- NOTES: 2. The device functions according to the function table for V_{CC} between 18 V and $V_{(OVCC)}$, but only up to a maximum supply voltage of 33 V (no parameters specified). Exposure beyond 18 V for extended periods may affect device reliability.
3. Exposure beyond absolute-maximum-rated condition of junction temperature may affect device reliability.
4. No temperature gradient between DMOS transistor and temperature sensor.
5. With temperature gradient between DMOS transistor and temperature sensor in a typical application (DMOS transistor as heat source).

switching characteristics over recommended operating case temperature and supply voltage ranges (unless otherwise noted)

PARAMETER		TEST CONDITIONS		MIN	TYP	MAX	UNIT
$t_{out(on)}$	High-side driver turn-on time	$V_{DS(on)} < 1$ V at 1 A, $V_{CC} = 13.2$ V				100	μs
	Low-side driver turn-on time				100		
SR	Slew rate, low-to-high sinusoidal ($\delta V/\delta t$)	$V_{CC} = 13.2$ V, $I_O = 1$ A resistive load		1		6	V/ μs
	Slew rate, high-to-low sinusoidal ($\delta V/\delta t$)			1		6	
$t_d(QCD)$	Under current spike duration to trigger open circuit detection	$V_{CC} = 5$ V to 18 V		1		10	ms
$t_d(CS)$	Delay time for over current shutdown			5	10	25	μs

TPIC0108B PWM CONTROL INTELLIGENT H-BRIDGE

SLIS068A – NOVEMBER1998 – REVISED APRIL 2002

thermal resistance

PARAMETER		MIN	MAX	UNIT
$R_{\theta JA}$	Junction-to-ambient thermal resistance		97	°C/W
$R_{\theta JC}$	Junction-to-case thermal resistance		5	°C/W

PARAMETER MEASUREMENT INFORMATION

Maximum continuous bridge current versus time based on 50 FITs at 100,000 hours operating life (90% confidence model)

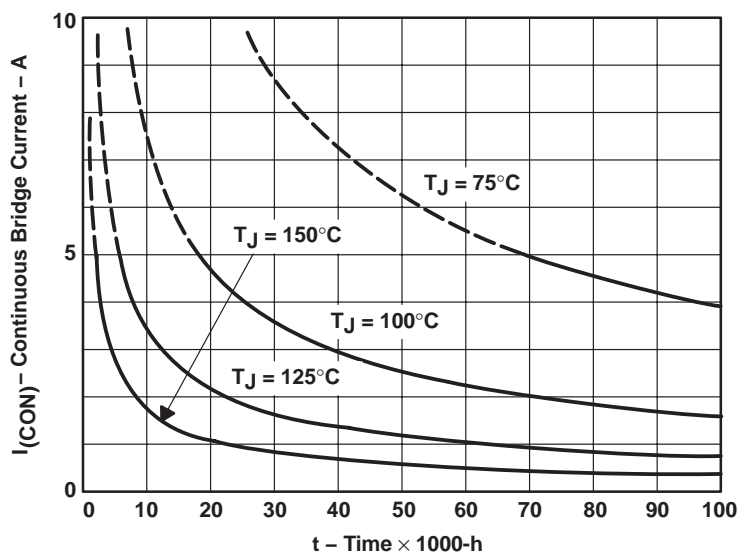

Figure 1. Electromigration Reliability Data

Example:

Average continuous bridge current, I_{CON}	Average junction temperature, T_J	Operating lifetime of device based on electromigration
2 A	125°C	>20,000 h
3 A	125°C	>10,000 h

PARAMETER MEASUREMENT INFORMATION

operating wave forms

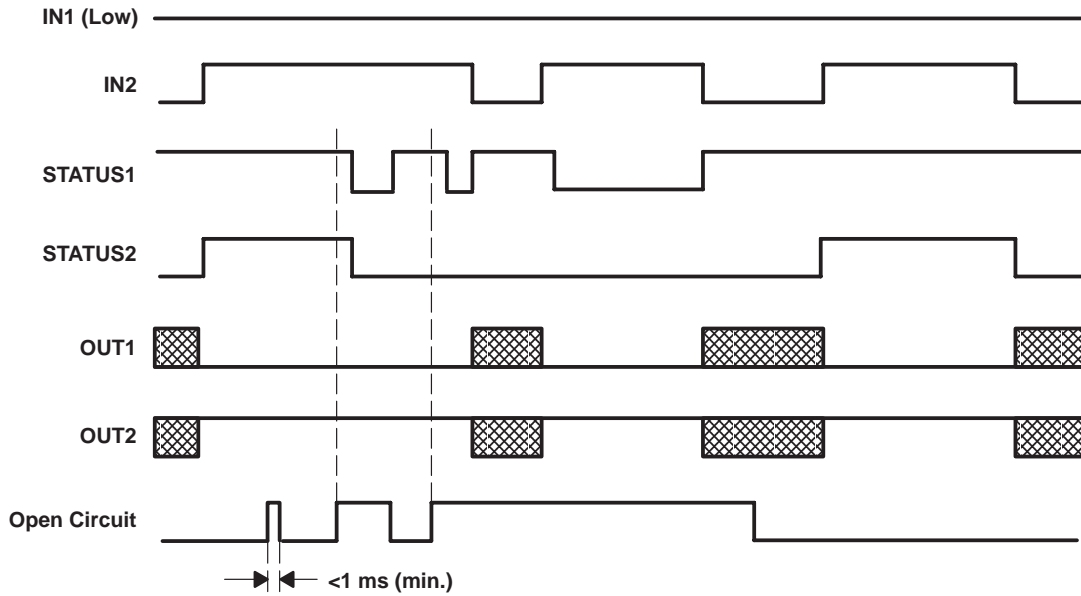

Figure 2. Open Circuit

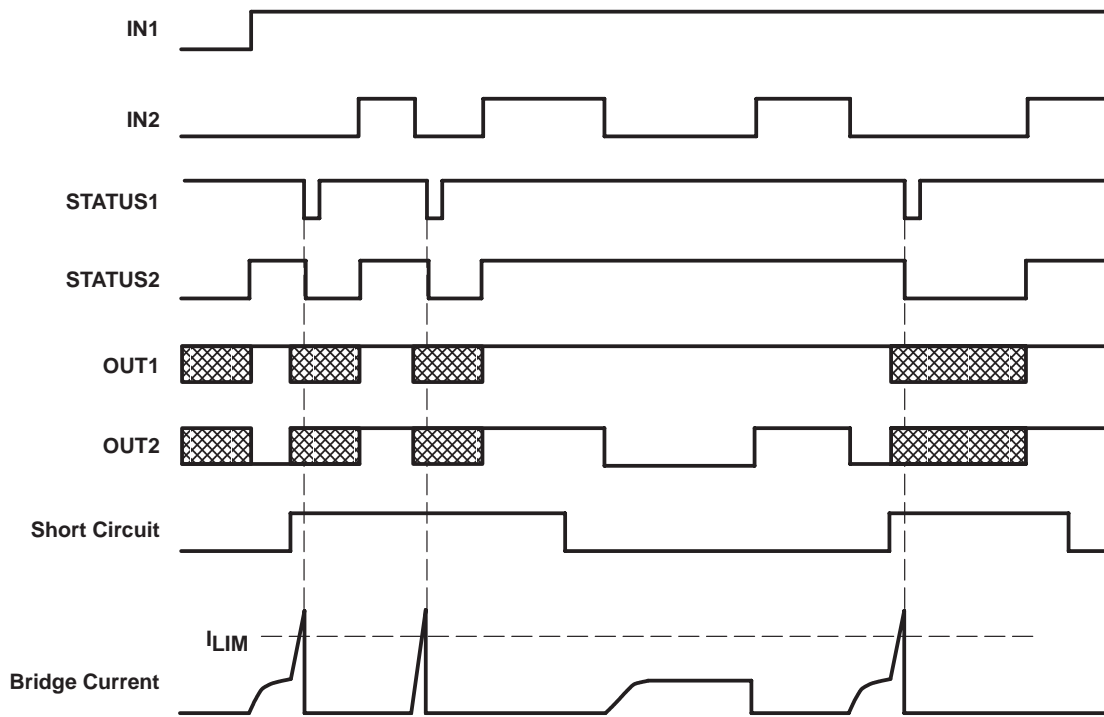

Figure 3. Short Circuit (e.g., OUT2 to V_{CC})

TPIC0108B PWM CONTROL INTELLIGENT H-BRIDGE

SLIS068A – NOVEMBER1998 – REVISED APRIL 2002

PARAMETER MEASUREMENT INFORMATION

operating wave forms (continued)

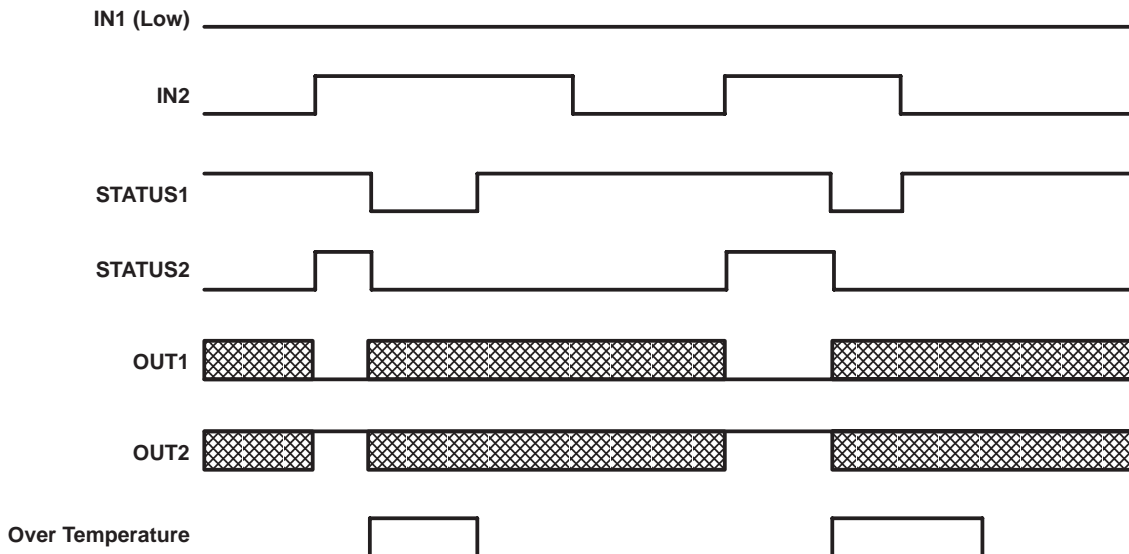

Figure 4. Over Temperature

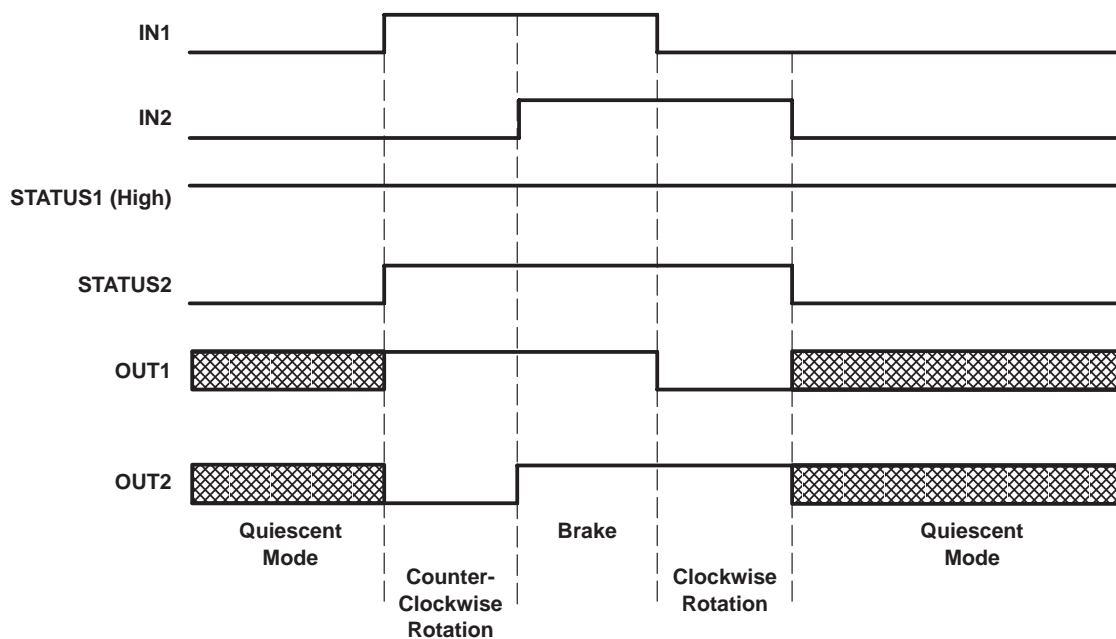

Figure 5. No Fault

PRINCIPLES OF OPERATION

protective functions and diagnostics†

over current/short circuit‡

The TPIC0108B detects shorts to V_{CC} , ground, or across the load being driven, by comparing the V_{DS} voltage drop across the DMOS outputs against the threshold voltage. The DMOS outputs of the TPIC0108B will be disabled and the fault flags will be generated 10 μ s after an over-current or short-circuit fault is detected. This 10 μ s delay is long enough to serve as a de-glitch filter for high current transients, yet short enough to prevent damage to the DMOS outputs. The DMOS outputs remain latched off until either IN1 or IN2 input is toggled.

In cases where the outputs have a continuous short-to-ground or when enabled from quiescent mode with a short-to-ground already exists (current rise time faster than 0.5 A/ μ s in both instances), the over-current shutdown threshold will decrease to 3 A to reduce power dissipation. This reduction to 3 A is achieved since the DMOS outputs will not be fully enhanced when the over-current threshold is reached if the current rise time exceeds 0.5 A/ μ s. Over-current and/or short-circuit protection is provided up to $V_{CC} = 16.5$ V and a junction temperature of 90°C.

over temperature

The TPIC0108B disables all DMOS outputs and the fault flags will be set when $T_J \geq 140^\circ\text{C}$ (min.). The DMOS outputs remain latched off until either IN1 or IN2 input is toggled.

under voltage

The TPIC0108B disables all DMOS outputs when $V_{CC} \leq V_{(UVCC)}$. The outputs will be re-enabled when $V_{CC} \geq V_{(UVCC)}$. No fault flags are set when under-voltage lockout occurs.

over voltage

In order to protect the DMOS outputs from damage caused by excessive supply voltage, the TPIC0108B disables all outputs when $V_{CC} \geq V_{(OVCC)}$. Once $V_{CC} \leq V_{(OVCC)}$, either IN1 or IN2 input must be toggled to re-enable the DMOS outputs.

cross conduction

Monitoring circuitry for each transistor detects whether the particular transistor is active to prevent the HSD or LSD of the corresponding half H-bridge from conducting.

open circuit

During operation, the bridge current is controlled continuously. If the bridge current is >10 mA (min.) for a period >1 ms (min.), the fault flags are set. However, the output transistors will not be disabled.

† All limits mentioned are typical values unless otherwise noted.

‡ If a short circuit occurs (i.e., the over-current detection circuitry is activated) at a supply voltage higher than 16.5 V and a junction temperature higher than 90°C, damage to the device may occur.

TPIC0108B

PWM CONTROL INTELLIGENT H-BRIDGE

SLIS068A – NOVEMBER1998 – REVISED APRIL 2002

PRINCIPLES OF OPERATION

DIAGNOSTICS TABLE (see Note 6)

FLAG	IN1	IN2	OUT1	OUT2	STATUS1†	STATUS2
Normal operation	0	0	Z	Z	1	0‡
	0	1	LS	HS	1	1
	1	0	HS	LS	1	1
	1	1	HS	HS	1	1
Open circuit between OUT1 and OUT2	0	0	Z	Z	1	0‡
	0	1	LS	HS	0	0
	1	0	HS	LS	0	0
	1	1	HS	HS	1	1
Short circuit from OUT1 to OUT2 (see Notes 7 and 8)	0	1	X	X	0	0
	1	0	X	X	0	0
Short circuit from OUT1 to GND (see Notes 7 and 8)	1	0	X	X	0	0
	1	1	X	X	0	0
Short circuit from OUT2 to GND (see Notes 7 and 8)	0	1	X	X	0	0
	1	1	X	X	0	0
Short circuit from OUT1 to V _{CC} (see Notes 7 and 8)	0	1	X	X	0	0
Short circuit from OUT2 to V _{CC} (see Notes 7 and 8)	1	0	X	X	0	0
Over temperature (see Note 9)	0	0	Z	Z	1	0‡
	0	1	Z	Z	0	0
	1	0	Z	Z	0	0
	1	1	Z	Z	0	0

† When wired with a pull-up resistor

‡ In quiescent mode, STATUS2 is pulled down to GND via an internal resistor.

SYMBOL VALUE

0	Logic low
1	Logic high
HS	High-side MOSFET conducting
LS	Low-side MOSFET conducting
Z	No output transistors conducting
X	Voltage level undefined

- NOTES: 6. All input combinations not stated result in STATUS output = 1.
 7. STATUS1 active for a minimum of 3 μ s.
 8. STATUS2 active until an input is toggled.
 9. Quiescent current consumption can occur only when the temperature drops below the thermal switch-off temperature.

TYPICAL CHARACTERISTICS

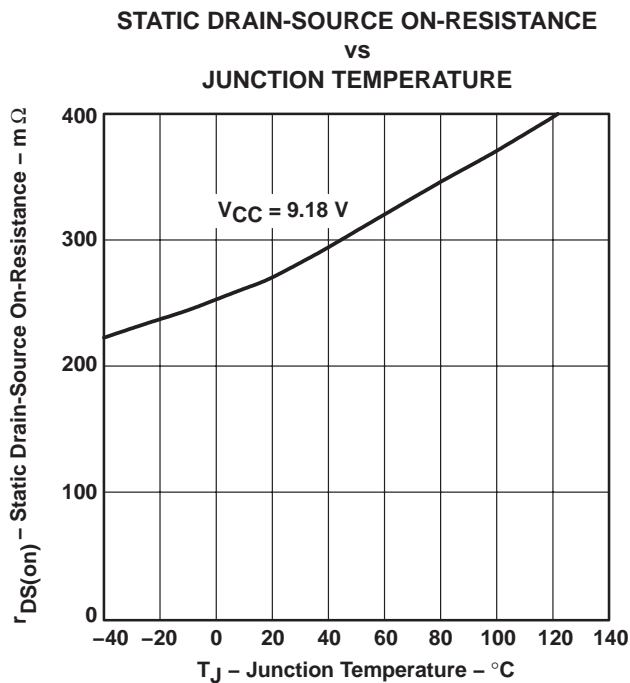

Figure 6

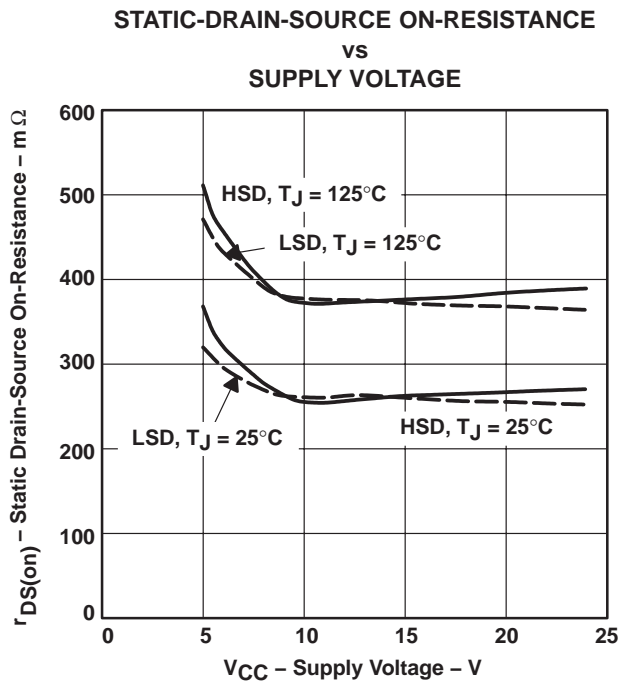

Figure 7

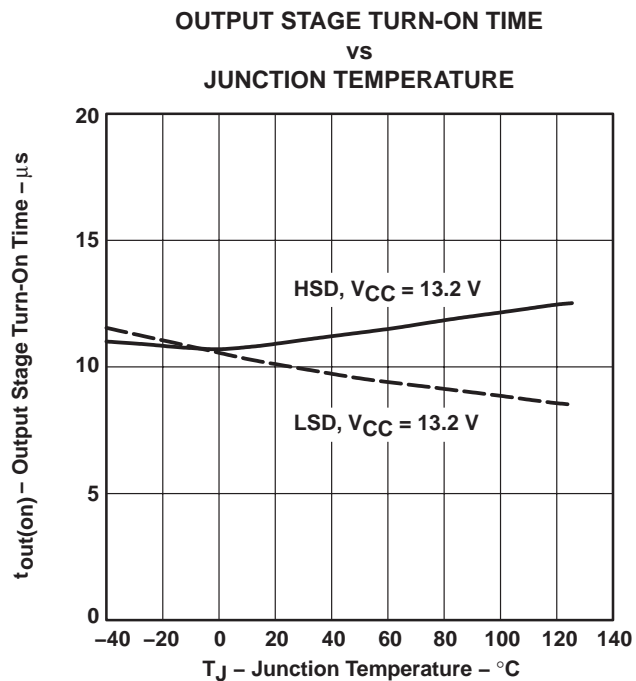

Figure 8

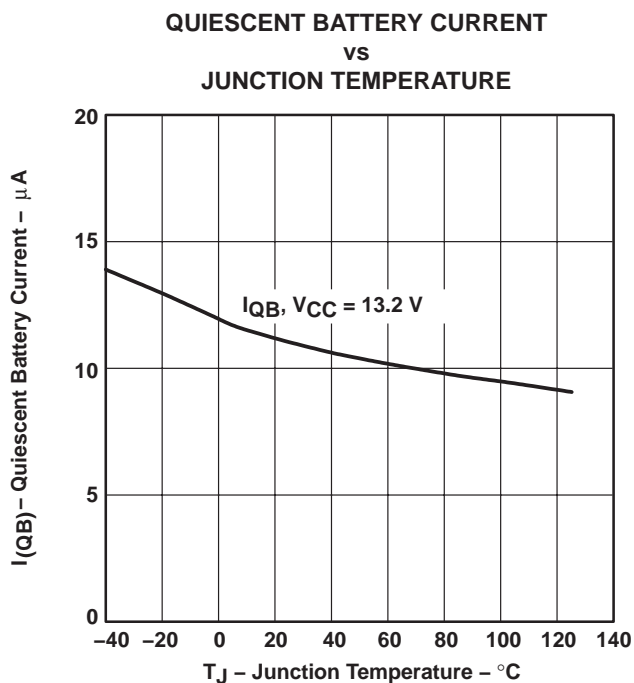
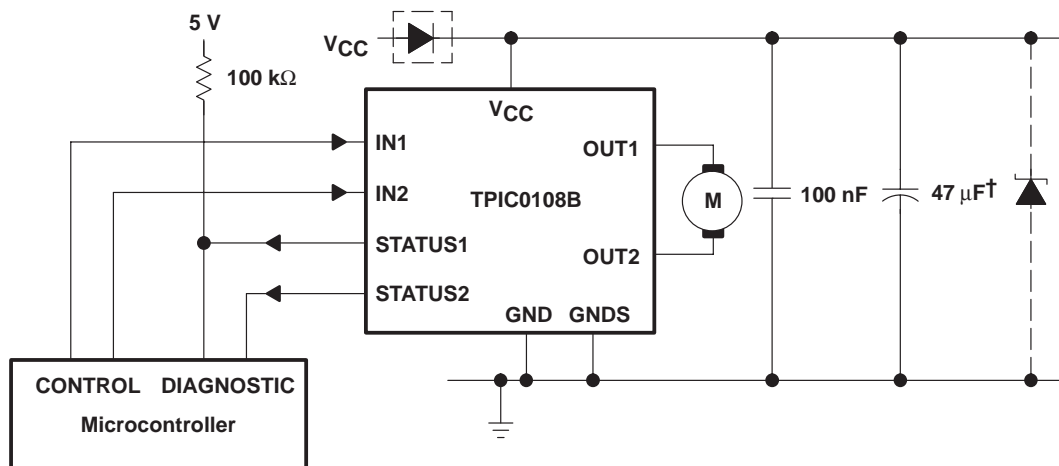

Figure 9

TPIC0108B PWM CONTROL INTELLIGENT H-BRIDGE

SLIS068A – NOVEMBER1998 – REVISED APRIL 2002

APPLICATION INFORMATION



† Necessary for isolating supply voltage or interruption (e.g., 47 µF).

NOTE: If a STATUS output is not connected to the appropriate microcontroller input, it shall remain unconnected.

recirculation current mode

When an inductive load (motor) is switched from one control mode to another, (i.e., forward to reverse) the TPIC0108B automatically enters a special recirculation current mode condition. This condition allows fast elimination of the recirculation currents caused by inductive switching. Once these currents have subsided to an acceptable level, the device automatically enters the requested state. This feature eliminates the need for either internally or externally connected free wheeling diodes and protects the TPIC0108B from damage due to high inductive voltage transients.

The recirculation current mode condition is triggered when the voltage at the HSD output voltage exceeds typically $V_{CC} + 0.7$ V. In this condition, a diode inherent in the HSD structure turns on. Simultaneously internal control circuitry turns on the opposite HSD, thus providing a current path for the recirculating currents.

Using TPIC0108B in PWM operation brake mode shall be applied before going into quiescent mode.

MECHANICAL DATA

DWP (R-PDSO-G**)

PowerPAD™ PLASTIC SMALL-OUTLINE PACKAGE

20 PINS SHOWN

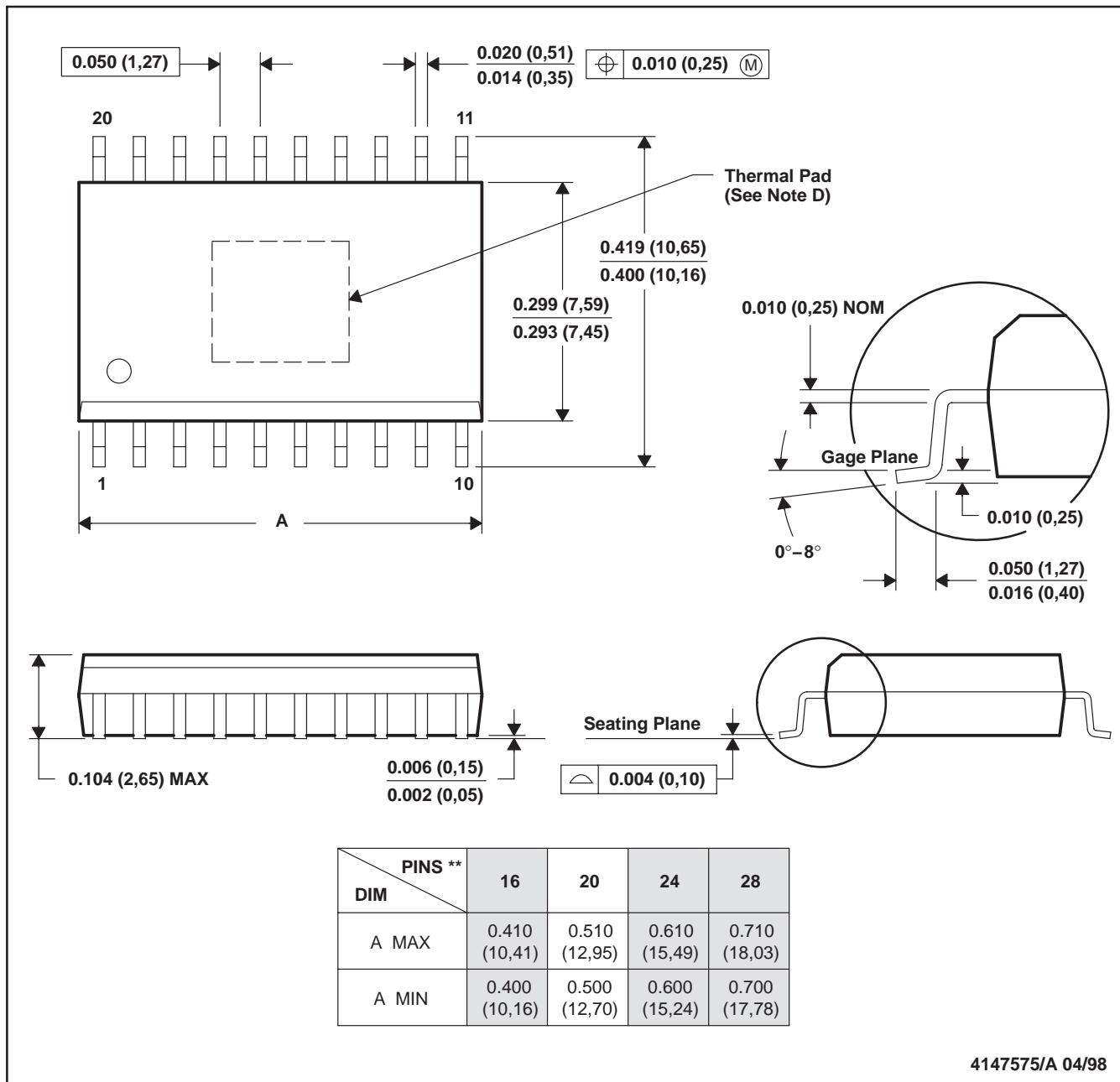

4147575/A 04/98

- NOTES: A. All linear dimensions are in inches (millimeters).
 B. This drawing is subject to change without notice.
 C. Body dimensions do not include mold flash or protrusion not to exceed 0.006 (0,15).
 D. The package thermal performance may be enhanced by bonding the thermal pad to an external thermal plane. This pad is electrically and thermally connected to the backside of the die and possibly selected leads.

PowerPAD is a trademark of Texas Instruments Incorporated.

PACKAGING INFORMATION

Orderable Device	Status ⁽¹⁾	Package Type	Package Drawing	Pins	Package Qty	Eco Plan ⁽²⁾	Lead/Ball Finish	MSL Peak Temp ⁽³⁾
TPIC0108BDWPR	OBSOLETE	SO Power PAD	DWP	20		TBD	Call TI	Call TI

⁽¹⁾ The marketing status values are defined as follows:

ACTIVE: Product device recommended for new designs.

LIFEBUY: TI has announced that the device will be discontinued, and a lifetime-buy period is in effect.

NRND: Not recommended for new designs. Device is in production to support existing customers, but TI does not recommend using this part in a new design.

PREVIEW: Device has been announced but is not in production. Samples may or may not be available.

OBSOLETE: TI has discontinued the production of the device.

⁽²⁾ Eco Plan - The planned eco-friendly classification: Pb-Free (RoHS), Pb-Free (RoHS Exempt), or Green (RoHS & no Sb/Br) - please check <http://www.ti.com/productcontent> for the latest availability information and additional product content details.

TBD: The Pb-Free/Green conversion plan has not been defined.

Pb-Free (RoHS): TI's terms "Lead-Free" or "Pb-Free" mean semiconductor products that are compatible with the current RoHS requirements for all 6 substances, including the requirement that lead not exceed 0.1% by weight in homogeneous materials. Where designed to be soldered at high temperatures, TI Pb-Free products are suitable for use in specified lead-free processes.

Pb-Free (RoHS Exempt): This component has a RoHS exemption for either 1) lead-based flip-chip solder bumps used between the die and package, or 2) lead-based die adhesive used between the die and leadframe. The component is otherwise considered Pb-Free (RoHS compatible) as defined above.

Green (RoHS & no Sb/Br): TI defines "Green" to mean Pb-Free (RoHS compatible), and free of Bromine (Br) and Antimony (Sb) based flame retardants (Br or Sb do not exceed 0.1% by weight in homogeneous material)

⁽³⁾ MSL, Peak Temp. -- The Moisture Sensitivity Level rating according to the JEDEC industry standard classifications, and peak solder temperature.

Important Information and Disclaimer:The information provided on this page represents TI's knowledge and belief as of the date that it is provided. TI bases its knowledge and belief on information provided by third parties, and makes no representation or warranty as to the accuracy of such information. Efforts are underway to better integrate information from third parties. TI has taken and continues to take reasonable steps to provide representative and accurate information but may not have conducted destructive testing or chemical analysis on incoming materials and chemicals. TI and TI suppliers consider certain information to be proprietary, and thus CAS numbers and other limited information may not be available for release.

In no event shall TI's liability arising out of such information exceed the total purchase price of the TI part(s) at issue in this document sold by TI to Customer on an annual basis.

DWP (R-PDSO-G**) 20 PINS SHOWN

PowerPAD™ PLASTIC SMALL-OUTLINE PACKAGE

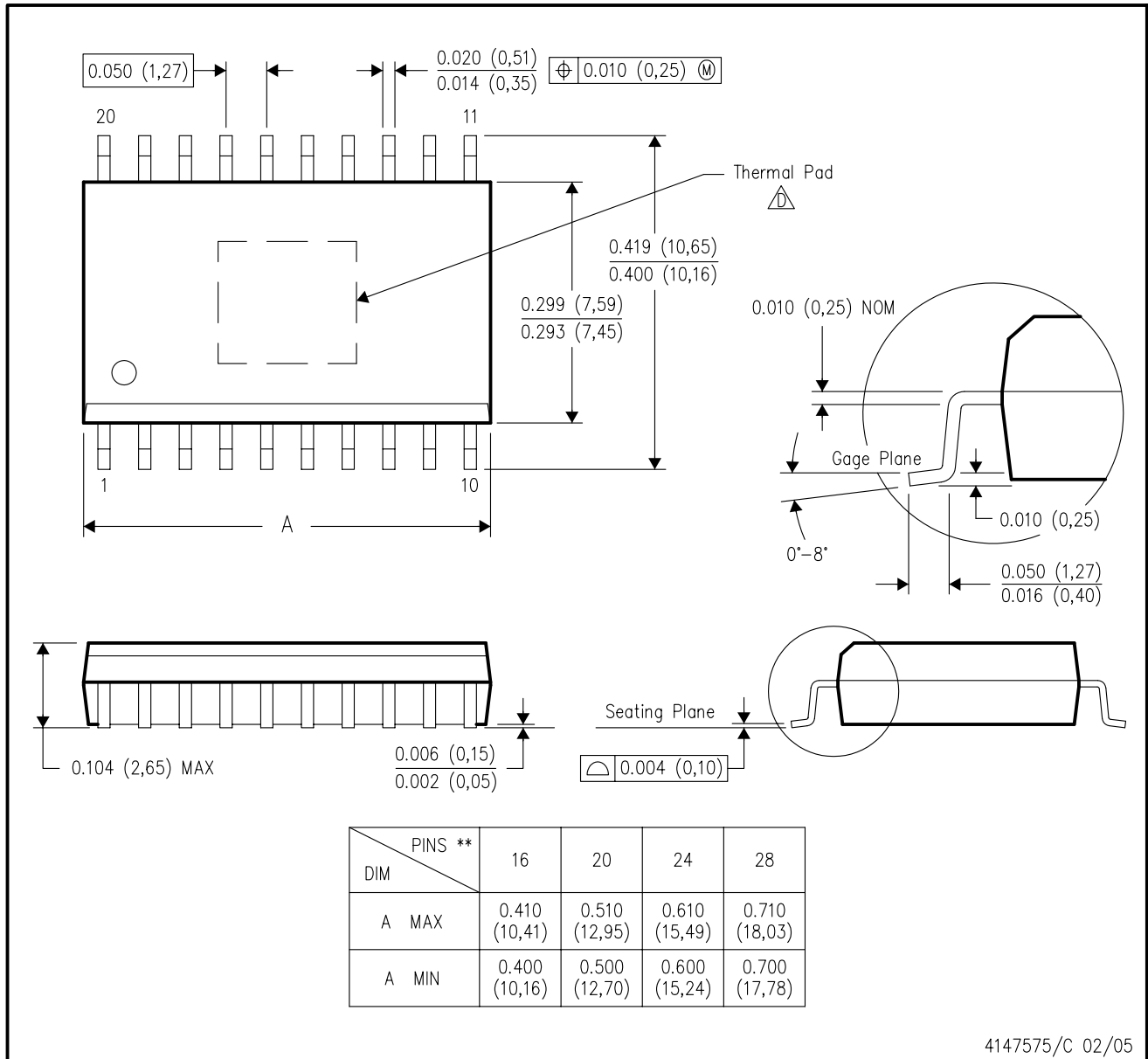

- NOTES:
- A. All linear dimensions are in inches (millimeters).
 - B. This drawing is subject to change without notice.
 - C. Body dimensions do not include mold flash or protrusion not to exceed 0.006 (0,15).
- Δ This package is designed to be soldered to a thermal pad on the board. Refer to Technical Brief, PowerPAD Thermally Enhanced Package, Texas Instruments Literature No. SLMA002 for information regarding recommended board layout. This document is available at www.ti.com <<http://www.ti.com>>. See the product data sheet for details regarding the exposed thermal pad dimensions.

PowerPAD is a trademark of Texas Instruments.

IMPORTANT NOTICE

Texas Instruments Incorporated and its subsidiaries (TI) reserve the right to make corrections, modifications, enhancements, improvements, and other changes to its products and services at any time and to discontinue any product or service without notice. Customers should obtain the latest relevant information before placing orders and should verify that such information is current and complete. All products are sold subject to TI's terms and conditions of sale supplied at the time of order acknowledgment.

TI warrants performance of its hardware products to the specifications applicable at the time of sale in accordance with TI's standard warranty. Testing and other quality control techniques are used to the extent TI deems necessary to support this warranty. Except where mandated by government requirements, testing of all parameters of each product is not necessarily performed.

TI assumes no liability for applications assistance or customer product design. Customers are responsible for their products and applications using TI components. To minimize the risks associated with customer products and applications, customers should provide adequate design and operating safeguards.

TI does not warrant or represent that any license, either express or implied, is granted under any TI patent right, copyright, mask work right, or other TI intellectual property right relating to any combination, machine, or process in which TI products or services are used. Information published by TI regarding third-party products or services does not constitute a license from TI to use such products or services or a warranty or endorsement thereof. Use of such information may require a license from a third party under the patents or other intellectual property of the third party, or a license from TI under the patents or other intellectual property of TI.

Reproduction of TI information in TI data books or data sheets is permissible only if reproduction is without alteration and is accompanied by all associated warranties, conditions, limitations, and notices. Reproduction of this information with alteration is an unfair and deceptive business practice. TI is not responsible or liable for such altered documentation. Information of third parties may be subject to additional restrictions.

Resale of TI products or services with statements different from or beyond the parameters stated by TI for that product or service voids all express and any implied warranties for the associated TI product or service and is an unfair and deceptive business practice. TI is not responsible or liable for any such statements.

TI products are not authorized for use in safety-critical applications (such as life support) where a failure of the TI product would reasonably be expected to cause severe personal injury or death, unless officers of the parties have executed an agreement specifically governing such use. Buyers represent that they have all necessary expertise in the safety and regulatory ramifications of their applications, and acknowledge and agree that they are solely responsible for all legal, regulatory and safety-related requirements concerning their products and any use of TI products in such safety-critical applications, notwithstanding any applications-related information or support that may be provided by TI. Further, Buyers must fully indemnify TI and its representatives against any damages arising out of the use of TI products in such safety-critical applications.

TI products are neither designed nor intended for use in military/aerospace applications or environments unless the TI products are specifically designated by TI as military-grade or "enhanced plastic." Only products designated by TI as military-grade meet military specifications. Buyers acknowledge and agree that any such use of TI products which TI has not designated as military-grade is solely at the Buyer's risk, and that they are solely responsible for compliance with all legal and regulatory requirements in connection with such use.

TI products are neither designed nor intended for use in automotive applications or environments unless the specific TI products are designated by TI as compliant with ISO/TS 16949 requirements. Buyers acknowledge and agree that, if they use any non-designated products in automotive applications, TI will not be responsible for any failure to meet such requirements.

Following are URLs where you can obtain information on other Texas Instruments products and application solutions:

Products

Amplifiers	amplifier.ti.com
Data Converters	dataconverter.ti.com
DLP® Products	www.dlp.com
DSP	dsp.ti.com
Clocks and Timers	www.ti.com/clocks
Interface	interface.ti.com
Logic	logic.ti.com
Power Mgmt	power.ti.com
Microcontrollers	microcontroller.ti.com
RFID	www.ti-rfid.com
RF/IF and ZigBee® Solutions	www.ti.com/lprf

Applications

Audio	www.ti.com/audio
Automotive	www.ti.com/automotive
Broadband	www.ti.com/broadband
Digital Control	www.ti.com/digitalcontrol
Medical	www.ti.com/medical
Military	www.ti.com/military
Optical Networking	www.ti.com/opticalnetwork
Security	www.ti.com/security
Telephony	www.ti.com/telephony
Video & Imaging	www.ti.com/video
Wireless	www.ti.com/wireless

Mailing Address: Texas Instruments, Post Office Box 655303, Dallas, Texas 75265
Copyright © 2009, Texas Instruments Incorporated