

# TMUX6136 $\pm 16.5$ -V, Low Capacitance, Low-Leakage-Current, Precision, Dual SPDT Switch

## 1 Features

- Wide Supply Range:  $\pm 5$  V to  $\pm 16.5$  V (dual) or 10 V to 16.5 V (single)
- Latch-Up Performance Meets 100 mA per JESD78 Class II Level A on all Pins
- Low On-Capacitance: 5.5 pF
- Low Input Leakage: 0.5 pA
- Low Charge Injection:  $-0.4$  pC
- Rail-to-Rail Operation
- Low On-Resistance: 120  $\Omega$
- Fast Transition Time: 66 ns
- Break-Before-Make Switching Action
- SELx Pin Connectable to  $V_{DD}$  With Integrated Pull-down
- Logic Levels: 2 V to  $V_{DD}$
- Low Supply Current: 17  $\mu$ A
- Human Body Model (HBM) ESD Protection:  $\pm 2$  kV on All Pins
- Industry-Standard TSSOP Package

## 2 Applications

- Factory Automation and Industrial Process Controls
- Programmable Logic Controllers (PLC)
- Analog Input Modules
- ATE Test Equipment
- Digital Multimeters
- Battery Monitoring Systems

## 3 Description

The TMUX6136 is a complementary metal-oxide semiconductor (CMOS) analog switch containing two independently selectable SPDT switches. The devices work well with dual supplies ( $\pm 5$  V to  $\pm 16.5$  V), a single supply (10 V to 16.5 V), or asymmetric supplies. The digital select pin (SELx) has transistor-transistor logic (TTL) compatible thresholds, ensuring TTL/CMOS logic compatibility.

The TMUX6136 switches one of two inputs ( $S_x$ ) to a common output (D), depending on the status of the SELx pins. Each switch conducts equally well in both directions in the ON position and supports input signal range up to the supplies. In the OFF condition, signal levels up to the supplies are blocked. All switches exhibit break-before-make (BBM) switching action.

The TMUX6136 is part of Texas Instruments Precision Switches and Multiplexers family. The device has very low leakage current and charge injection, allowing them to be used in high-precision measurement applications. The device also provides excellent isolation by blocking signal levels up to the supplies when the switches are in the OFF position. Low supply current of 17  $\mu$ A enables usage in portable applications.

### Device Information<sup>(1)</sup>

PART NUMBER	PACKAGE	BODY SIZE (NOM)
TMUX6136	TSSOP (16)	5.00 mm x 4.40 mm

(1) For all available packages, see the package option addendum at the end of the data sheet.

### Simplified Schematic

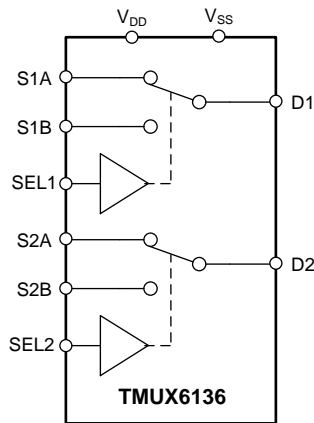

Copyright © 2018, Texas Instruments Incorporated



## Table of Contents

<b>1 Features</b> .....	<b>1</b>	7.3 Feature Description .....	<b>18</b>
<b>2 Applications</b> .....	<b>1</b>	7.4 Device Functional Modes .....	<b>19</b>
<b>3 Description</b> .....	<b>1</b>	<b>8 Application and Implementation</b> .....	<b>20</b>
<b>4 Revision History</b> .....	<b>2</b>	8.1 Application Information .....	<b>20</b>
<b>5 Pin Configuration and Functions</b> .....	<b>3</b>	8.2 Typical Application .....	<b>20</b>
<b>6 Specifications</b> .....	<b>4</b>	<b>9 Power Supply Recommendations</b> .....	<b>22</b>
6.1 Absolute Maximum Ratings .....	<b>4</b>	<b>10 Layout</b> .....	<b>23</b>
6.2 ESD Ratings .....	<b>4</b>	10.1 Layout Guidelines .....	<b>23</b>
6.3 Thermal Information .....	<b>4</b>	10.2 Layout Example .....	<b>23</b>
6.4 Recommended Operating Conditions .....	<b>4</b>	<b>11 Device and Documentation Support</b> .....	<b>24</b>
6.5 Electrical Characteristics (Dual Supplies: $\pm 15$ V) .....	<b>5</b>	11.1 Documentation Support .....	<b>24</b>
6.6 Switching Characteristics (Dual Supplies: $\pm 15$ V) .....	<b>6</b>	11.2 Receiving Notification of Documentation Updates .....	<b>24</b>
6.7 Electrical Characteristics (Single Supply: 12 V) .....	<b>7</b>	11.3 Community Resources .....	<b>24</b>
6.8 Switching Characteristics (Single Supply: 12 V) .....	<b>7</b>	11.4 Trademarks .....	<b>24</b>
6.9 Typical Characteristics .....	<b>9</b>	11.5 Electrostatic Discharge Caution .....	<b>24</b>
<b>7 Detailed Description</b> .....	<b>12</b>	11.6 Glossary .....	<b>24</b>
7.1 Overview .....	<b>12</b>	<b>12 Mechanical, Packaging, and Orderable Information</b> .....	<b>24</b>
7.2 Functional Block Diagram .....	<b>18</b>		

## 4 Revision History

NOTE: Page numbers for previous revisions may differ from page numbers in the current version.

DATE	REVISION	NOTES
November 2018	*	Initial release.

## 5 Pin Configuration and Functions

**PW Package  
16-Pin TSSOP  
Top View**

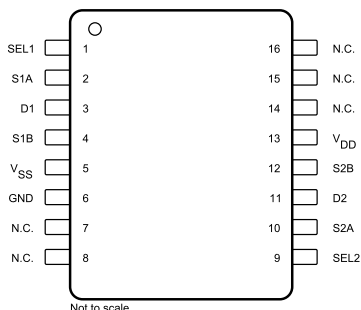

### Pin Functions

PIN		TYPE	DESCRIPTION
NAME	NO.		
SEL1	1	I	Select line 0
S1A	2	I/O	Source pin 1A. Can be an input or output.
D1	3	I/O	Drain pin D1. Can be an input or output.
S1B	4	I/O	Source pin 1B. Can be an input or output.
V <sub>SS</sub>	5	P	Negative power supply. This pin is the most negative power-supply potential. In single-supply applications, this pin can be connected to ground. For reliable operation, connect a decoupling capacitor ranging from 0.1 $\mu$ F to 10 $\mu$ F between V <sub>SS</sub> and GND.
GND	6		Ground (0 V) reference
N.C.	7, 8, 14, 15, 16	No Connect	No internal connection
SEL2	9	I	Select line 1
S2A	10	I/O	Source pin 2A. Can be an input or output.
D2	11	I/O	Drain pin D2. Can be an input or output.
S2B	12	I/O	Source pin 2B. Can be an input or output.
V <sub>DD</sub>	13	P	Positive power supply. This pin is the most positive power-supply potential. For reliable operation, connect a decoupling capacitor ranging from 0.1 $\mu$ F to 10 $\mu$ F between V <sub>DD</sub> and GND.

## 6 Specifications

### 6.1 Absolute Maximum Ratings

over operating free-air temperature range (unless otherwise noted)<sup>(1)</sup>

		MIN	MAX	UNIT
V <sub>DD</sub> to V <sub>SS</sub>	Supply voltage		36	V
V <sub>DD</sub> to GND		-0.3	18	V
V <sub>SS</sub> to GND		-18	0.3	V
V <sub>DIG</sub>	Digital input pin (SEL1, SEL2) voltage	GND -0.3	V <sub>DD</sub> +0.3	V
I <sub>DIG</sub>	Digital input pin (SEL1, SEL2) current	-30	30	mA
V <sub>ANA_IN</sub>	Analog input pin (Sx) voltage	V <sub>SS</sub> -0.3	V <sub>DD</sub> +0.3	V
I <sub>ANA_IN</sub>	Analog input pin (Sx) current	-30	30	mA
V <sub>ANA_OUT</sub>	Analog output pin (D) voltage	V <sub>SS</sub> -0.3	V <sub>DD</sub> +0.3	V
I <sub>ANA_OUT</sub>	Analog output pin (D) current	-30	30	mA
T <sub>A</sub>	Ambient temperature	-55	140	°C
T <sub>J</sub>	Junction temperature		150	°C
T <sub>stg</sub>	Storage temperature	-65	150	°C

(1) Stresses beyond those listed under *Absolute Maximum Rating* may cause permanent damage to the device. These are stress ratings only, which do not imply functional operation of the device at these or any other conditions beyond those indicated under *Recommended Operating Condition*. Exposure to absolute-maximum-rated conditions for extended periods may affect device reliability.

### 6.2 ESD Ratings

			VALUE	UNIT
V <sub>(ESD)</sub>	Electrostatic discharge	Human body model (HBM), per ANSI/ESDA/JEDEC JS-001, all pins <sup>(1)</sup>	±2000	V
		Charged device model (CDM), per JEDEC specification JESD22-C101, all pins <sup>(2)</sup>	±500	

(1) JEDEC document JEP155 states that 500-V HBM allows safe manufacturing with a standard ESD control process.

(2) JEDEC document JEP157 states that 250-V CDM allows safe manufacturing with a standard ESD control process.

### 6.3 Thermal Information

THERMAL METRIC <sup>(1)</sup>		TMUX6136	UNIT
		PW (TSSOP)	
		16 PINS	
R <sub>θJA</sub>	Junction-to-ambient thermal resistance	111.0	°C/W
R <sub>θJC(top)</sub>	Junction-to-case (top) thermal resistance	41.7	°C/W
R <sub>θJB</sub>	Junction-to-board thermal resistance	57.2	°C/W
Ψ <sub>JT</sub>	Junction-to-top characterization parameter	4.1	°C/W
Ψ <sub>JB</sub>	Junction-to-board characterization parameter	56.6	°C/W
R <sub>θJC(bot)</sub>	Junction-to-case (bottom) thermal resistance	N/A	°C/W

(1) For more information about traditional and new thermal metrics, see the [Semiconductor and IC Package Thermal Metrics](#) application report.

### 6.4 Recommended Operating Conditions

over operating free-air temperature range (unless otherwise noted)

		MIN	NOM	MAX	UNIT
V <sub>DD(1)</sub> to V <sub>SS</sub>	Power supply voltage differential	10		33	V
V <sub>DD</sub> to GND	Positive power supply voltage (single supply, V <sub>SS</sub> = 0 V)	10		16.5	V

(1) V<sub>DD</sub> and V<sub>SS</sub> can be any value as long as 10 V ≤ (V<sub>DD</sub> - V<sub>SS</sub>) ≤ 33 V.

## Recommended Operating Conditions (continued)

over operating free-air temperature range (unless otherwise noted)

		MIN	NOM	MAX	UNIT
$V_{DD}$ to GND	Positive power supply voltage (dual supply)	5		16.5	V
$V_{SS}$ to GND	Negative power supply voltage (dual supply)	-16.5		-5	V
$V_S$ <sup>(1)</sup>	Source pins voltage	$V_{SS}$		$V_{DD}$	V
$V_D$	Drain pin voltage	$V_{SS}$		$V_{DD}$	V
$V_{DIG}$	Digital input pin (SEL1, SEL2) voltage	0		$V_{DD}$	V
$I_{CH}$	Channel current ( $T_A = 25^\circ\text{C}$ )	-25		25	mA
$T_A$	Ambient temperature	-40		125	$^\circ\text{C}$

## 6.5 Electrical Characteristics (Dual Supplies: $\pm 15$ V)

at  $T_A = 25^\circ\text{C}$ ,  $V_{DD} = 15$  V, and  $V_{SS} = -15$  V (unless otherwise noted)

PARAMETER	TEST CONDITIONS	TEST CONDITIONS	MIN	TYP	MAX	UNIT		
<b>ANALOG SWITCH</b>								
$V_A$	Analog signal range		$T_A = -40^\circ\text{C}$ to $+125^\circ\text{C}$	$V_{SS}$	$V_{DD}$	V		
$R_{ON}$	On-resistance	$V_S = 0$ V, $I_S = 1$ mA		120	135	$\Omega$		
				140	160	$\Omega$		
		$V_S = \pm 10$ V, $I_S = 1$ mA	$T_A = -40^\circ\text{C}$ to $+85^\circ\text{C}$		210		$\Omega$	
			$T_A = -40^\circ\text{C}$ to $+125^\circ\text{C}$		245		$\Omega$	
$\Delta R_{ON}$	On-resistance mismatch between channels	$V_S = \pm 10$ V, $I_S = 1$ mA		2.5	6	$\Omega$		
			$T_A = -40^\circ\text{C}$ to $+85^\circ\text{C}$		9	$\Omega$		
			$T_A = -40^\circ\text{C}$ to $+125^\circ\text{C}$		11	$\Omega$		
$R_{ON\_FLAT}$	On-resistance flatness	$V_S = -10$ V, 0 V, +10 V, $I_S = 1$ mA		23	33	$\Omega$		
			$T_A = -40^\circ\text{C}$ to $+85^\circ\text{C}$		35	$\Omega$		
			$T_A = -40^\circ\text{C}$ to $+125^\circ\text{C}$		37	$\Omega$		
$R_{ON\_DRIFT}$	On-resistance drift	$V_S = 0$ V		0.42		$\%/^\circ\text{C}$		
$I_{S(OFF)}$	Source off leakage current <sup>(1)</sup>	Switch state is off, $V_S = +10$ V/ $-10$ V, $V_D = -10$ V/ $+10$ V		-0.05	0.005	0.05	nA	
		Switch state is off, $V_S = +10$ V/ $-10$ V, $V_D = -10$ V/ $+10$ V	$T_A = -40^\circ\text{C}$ to $+85^\circ\text{C}$	-0.17		0.1	nA	
		Switch state is off, $V_S = +10$ V/ $-10$ V, $V_D = -10$ V/ $+10$ V	$T_A = -40^\circ\text{C}$ to $+125^\circ\text{C}$	-1		0.25	nA	
$I_{D(ON)}$	Drain on leakage current	Switch state is on, $V_S = +10$ V/ $-10$ V, $V_D = -10$ V/ $+10$ V		-0.06	0.008	0.06	nA	
			$T_A = -40^\circ\text{C}$ to $+85^\circ\text{C}$		-0.25		0.15	nA
			$T_A = -40^\circ\text{C}$ to $+125^\circ\text{C}$		-1.6		0.4	nA
<b>DIGITAL INPUT (EN, Ax pins)</b>								
$V_{IH}$	Logic voltage high			2		V		
$V_{IL}$	Logic voltage low				0.8	V		
$R_{PD(EN)}$	Pull-down resistance on EN pin			6		M $\Omega$		
<b>POWER SUPPLY</b>								
$I_{DD}$	$V_{DD}$ supply current	$V_A = 0$ V or 3.3 V, $V_S = 0$ V		17	21	$\mu\text{A}$		
			$T_A = -40^\circ\text{C}$ to $+85^\circ\text{C}$		22	$\mu\text{A}$		
			$T_A = -40^\circ\text{C}$ to $+125^\circ\text{C}$		23	$\mu\text{A}$		

(1) When  $V_S$  is positive,  $V_D$  is negative, and vice versa.

## Electrical Characteristics (Dual Supplies: $\pm 15$ V) (continued)

 at  $T_A = 25^\circ\text{C}$ ,  $V_{DD} = 15$  V, and  $V_{SS} = -15$  V (unless otherwise noted)

PARAMETER		TEST CONDITIONS	TEST CONDITIONS	MIN	TYP	MAX	UNIT
$I_{SS}$	$V_{SS}$ supply current	$V_A = 0$ V or 3.3 V, $V_S = 0$ V			8	10	$\mu\text{A}$
			$T_A = -40^\circ\text{C}$ to $+85^\circ\text{C}$			11	$\mu\text{A}$
			$T_A = -40^\circ\text{C}$ to $+125^\circ\text{C}$			12	$\mu\text{A}$

## 6.6 Switching Characteristics (Dual Supplies: $\pm 15$ V)

 at  $T_A = 25^\circ\text{C}$ ,  $V_{DD} = 15$  V, and  $V_{SS} = -15$  V (unless otherwise noted)

PARAMETER		TEST CONDITIONS	MIN	TYP	MAX	UNIT
$t_{\text{TRAN}}$	Transition time	$V_S = 10$ V, $R_L = 300 \Omega$ , $C_L = 35$ pF		66	78	ns
		$V_S = 10$ V, $R_L = 300 \Omega$ , $C_L = 35$ pF, $T_A = -40^\circ\text{C}$ to $+85^\circ\text{C}$			107	ns
		$V_S = 10$ V, $R_L = 300 \Omega$ , $C_L = 35$ pF, $T_A = -40^\circ\text{C}$ to $+125^\circ\text{C}$			117	ns
$t_{\text{BBM}}$	Break-before-make time delay	$V_S = 10$ V, $R_L = 300 \Omega$ , $C_L = 35$ pF, $T_A = -40^\circ\text{C}$ to $+125^\circ\text{C}$	20	40		ns
$Q_J$	Charge injection	$V_S = 0$ V, $R_S = 0 \Omega$ , $C_L = 1$ nF		-0.4		pC
$O_{\text{ISO}}$	Off-isolation	$R_L = 50 \Omega$ , $C_L = 5$ pF, $f = 1$ MHz		-85		dB
$X_{\text{TALK}}$	Channel-to-channel crosstalk	$R_L = 50 \Omega$ , $C_L = 5$ pF, $f = 1$ MHz (Inter-channel: S1x & S2x)		-105		dB
		$R_L = 50 \Omega$ , $C_L = 5$ pF, $f = 1$ MHz (Intra-channel: SxA & SxB)		-92		dB
$I_L$	Insertion loss	$R_L = 50 \Omega$ , $C_L = 5$ pF, $f = 1$ MHz		-7		dB
ACPSRR	AC Power Supply Rejection Ratio	$R_L = 10$ k $\Omega$ , $C_L = 5$ pF, $V_{PP} = 0.62$ V on $V_{DD}$ , $f = 1$ MHz		-59		dB
		$R_L = 10$ k $\Omega$ , $C_L = 5$ pF, $V_{PP} = 0.62$ V on $V_{SS}$ , $f = 1$ MHz		-59		dB
BW	-3dB Bandwidth	$R_L = 50 \Omega$ , $C_L = 5$ pF		670		MHz
THD	Total harmonic distortion + noise	$R_L = 10$ k $\Omega$ , $C_L = 5$ pF, $f = 20$ Hz to 20 kHz		0.08		%
$C_{\text{IN}}$	Digital input capacitance	$V_{\text{IN}} = 0$ V or $V_{DD}$		1.5		pF
$C_{\text{S(OFF)}}$	Source off-capacitance	$V_S = 0$ V, $f = 1$ MHz		2.4	3.3	pF
$C_{\text{S(ON)}}$ , $C_{\text{D(ON)}}$	Source and drain on-capacitance	$V_S = 0$ V, $f = 1$ MHz		5.5	7.5	pF

## 6.7 Electrical Characteristics (Single Supply: 12 V)

at  $T_A = 25^\circ\text{C}$ ,  $V_{DD} = 12\text{ V}$ , and  $V_{SS} = 0\text{ V}$  (unless otherwise noted)

PARAMETER		TEST CONDITIONS		MIN	TYP	MAX	UNIT
<b>ANALOG SWITCH</b>							
$V_A$	Analog signal range			$V_{SS}$		$V_{DD}$	V
$R_{ON}$	On-resistance	$V_S = 10\text{ V}$ , $I_S = 1\text{ mA}$		235	345		$\Omega$
			$T_A = -40^\circ\text{C}$ to $+85^\circ\text{C}$			400	$\Omega$
			$T_A = -40^\circ\text{C}$ to $+125^\circ\text{C}$			440	$\Omega$
$\Delta R_{ON}$	On-resistance mismatch between channels	$V_S = 10\text{ V}$ , $I_S = 1\text{ mA}$		4	12		$\Omega$
			$T_A = -40^\circ\text{C}$ to $+85^\circ\text{C}$			19	$\Omega$
			$T_A = -40^\circ\text{C}$ to $+125^\circ\text{C}$			23	$\Omega$
$R_{ON\_DRIFT}$	On-resistance drift	$V_S = 0\text{ V}$		0.47			%/ $^\circ\text{C}$
$I_{S(OFF)}$	Source off leakage current <sup>(1)</sup>	Switch state is off, $V_S = 10\text{ V}/1\text{ V}$ , $V_D = 1\text{ V}/10\text{ V}$	$T_A = -40^\circ\text{C}$ to $+85^\circ\text{C}$	-0.03	0.005	0.03	nA
			$T_A = -40^\circ\text{C}$ to $+125^\circ\text{C}$	-0.1		0.07	nA
$I_{D(ON)}$	Drain on leakage current	Switch state is on, $V_S = \text{floating}$ , $V_D = 1\text{ V}/10\text{ V}$		-0.04	0.01	0.04	nA
			$T_A = -40^\circ\text{C}$ to $+85^\circ\text{C}$	-0.16		0.09	nA
			$T_A = -40^\circ\text{C}$ to $+125^\circ\text{C}$	-1.2		0.3	nA
<b>DIGITAL INPUT (EN, Ax pins)</b>							
$V_{IH}$	Logic voltage high			2			V
$V_{IL}$	Logic voltage low					0.8	V
$R_{PD(EN)}$	Pull-down resistance on EN pin				6		M $\Omega$
<b>POWER SUPPLY</b>							
$I_{DD}$	$V_{DD}$ supply current	$V_A = 0\text{ V}$ or $3.3\text{ V}$ , $V_S = 0\text{ V}$		13	16		$\mu\text{A}$
			$T_A = -40^\circ\text{C}$ to $+85^\circ\text{C}$			17	$\mu\text{A}$
			$T_A = -40^\circ\text{C}$ to $+125^\circ\text{C}$			18	$\mu\text{A}$

(1) When  $V_S$  is positive,  $V_D$  is negative, and vice versa.

## 6.8 Switching Characteristics (Single Supply: 12 V)

at  $T_A = 25^\circ\text{C}$ ,  $V_{DD} = 12\text{ V}$ , and  $V_{SS} = 0\text{ V}$  (unless otherwise noted)

PARAMETER		TEST CONDITIONS		MIN	TYP	MAX	UNIT
$t_{TRAN}$	Transition time	$V_S = 8\text{ V}$ , $R_L = 300\ \Omega$ , $C_L = 35\text{ pF}$			72	84	ns
		$V_S = 8\text{ V}$ , $R_L = 300\ \Omega$ , $C_L = 35\text{ pF}$ , $T_A = -40^\circ\text{C}$ to $+85^\circ\text{C}$				117	ns
		$V_S = 8\text{ V}$ , $R_L = 300\ \Omega$ , $C_L = 35\text{ pF}$ , $T_A = -40^\circ\text{C}$ to $+125^\circ\text{C}$				128	ns
$t_{BBM}$	Break-before-make time delay	$V_S = 8\text{ V}$ , $R_L = 300\ \Omega$ , $C_L = 35\text{ pF}$ , $T_A = -40^\circ\text{C}$ to $+125^\circ\text{C}$		20	40		ns
$Q_J$	Charge injection	$V_S = 6\text{ V}$ , $R_S = 0\ \Omega$ , $C_L = 1\text{ nF}$			-0.7		pC
$O_{ISO}$	Off-isolation	$R_L = 50\ \Omega$ , $C_L = 5\text{ pF}$ , $f = 1\text{ MHz}$			-85		dB
$X_{TALK}$	Channel-to-channel crosstalk	$R_L = 50\ \Omega$ , $C_L = 5\text{ pF}$ , $f = 1\text{ MHz}$ (Inter-channel: S1x & S2x)			-110		dB
		$R_L = 50\ \Omega$ , $C_L = 5\text{ pF}$ , $f = 1\text{ MHz}$ (Intra-channel: SxA & SxB)			-95		dB
$I_L$	Insertion loss	$R_L = 50\ \Omega$ , $C_L = 5\text{ pF}$ , $f = 1\text{ MHz}$			-13		dB
ACPSRR	AC Power Supply Rejection Ratio	$R_L = 10\text{ k}\Omega$ , $C_L = 5\text{ pF}$ , $V_{PP} = 0.62\text{ V}$ , $f = 1\text{ MHz}$			-58		dB
BW	-3dB Bandwidth	$R_L = 50\ \Omega$ , $C_L = 5\text{ pF}$			650		MHz
$C_{IN}$	Digital input capacitance	$V_{IN} = 0\text{ V}$ or $V_{DD}$			1.7		pF
$C_{S(OFF)}$	Source off-capacitance	$V_S = 6\text{ V}$ , $f = 1\text{ MHz}$			2.6	3.7	pF

**Switching Characteristics (Single Supply: 12 V) (continued)**

 at  $T_A = 25^\circ\text{C}$ ,  $V_{DD} = 12\text{ V}$ , and  $V_{SS} = 0\text{ V}$  (unless otherwise noted)

PARAMETER		TEST CONDITIONS	MIN	TYP	MAX	UNIT
$C_{S(ON)}$ , $C_{D(ON)}$	Source and drain on-capacitance	$V_S = 6\text{ V}$ , $f = 1\text{ MHz}$		6.3	8.5	pF

### 6.9 Typical Characteristics

at  $T_A = 25^\circ\text{C}$ ,  $V_{DD} = 15\text{ V}$ , and  $V_{SS} = -15\text{ V}$  (unless otherwise noted)

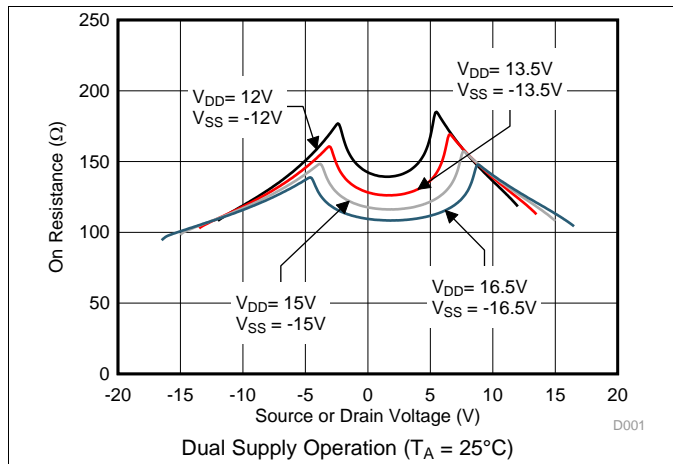

Figure 1. On-Resistance vs Source or Drain Voltage

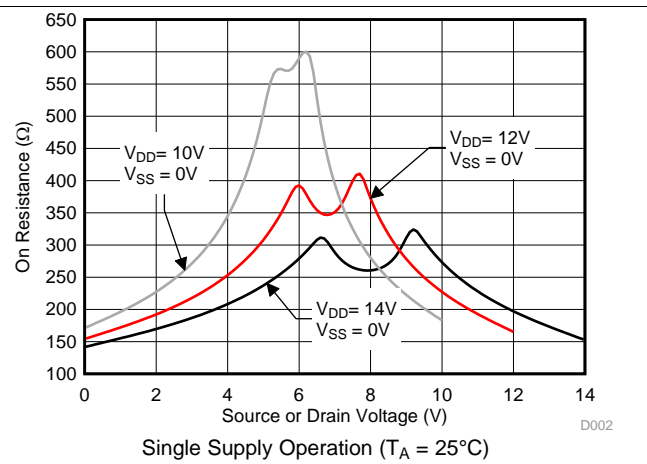

Figure 2. On-Resistance vs Source or Drain Voltage

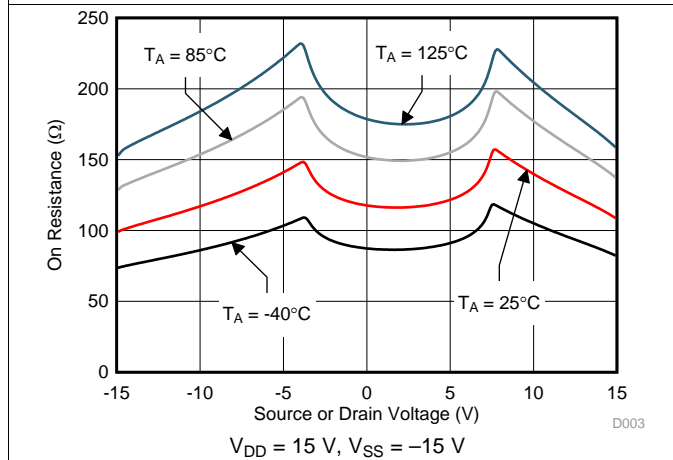

Figure 3. On-Resistance vs Source or Drain Voltage

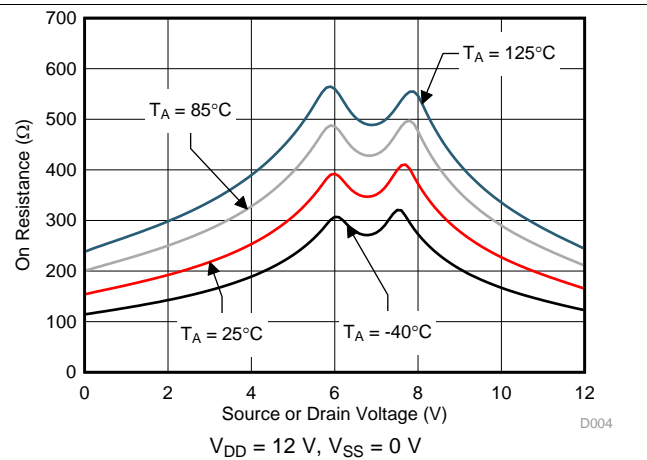

Figure 4. On-Resistance vs Source or Drain Voltage

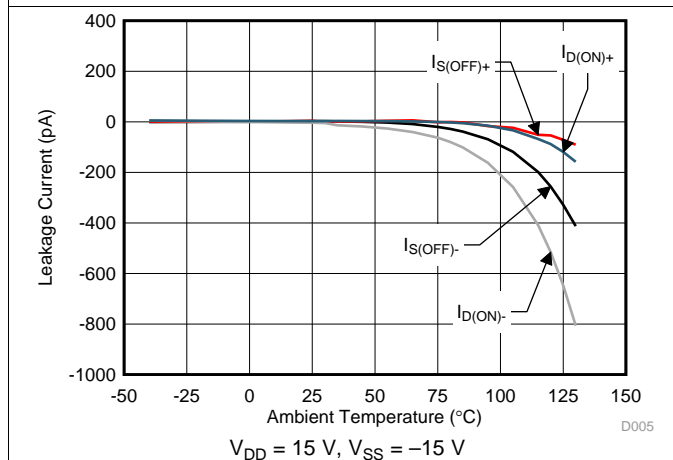

Figure 5. Leakage Current vs Temperature

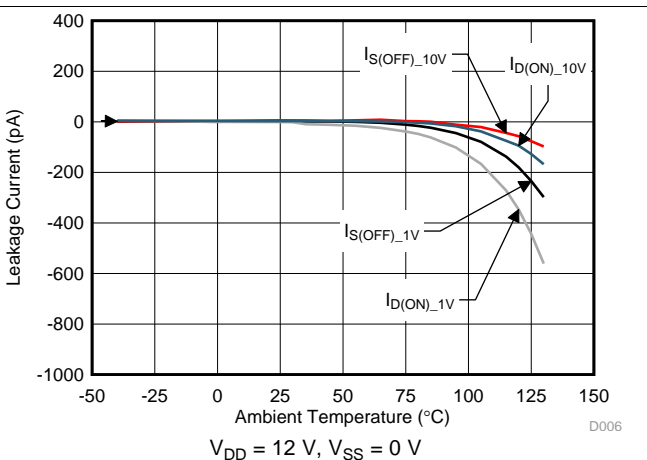

Figure 6. Leakage Current vs Temperature

Typical Characteristics (continued)

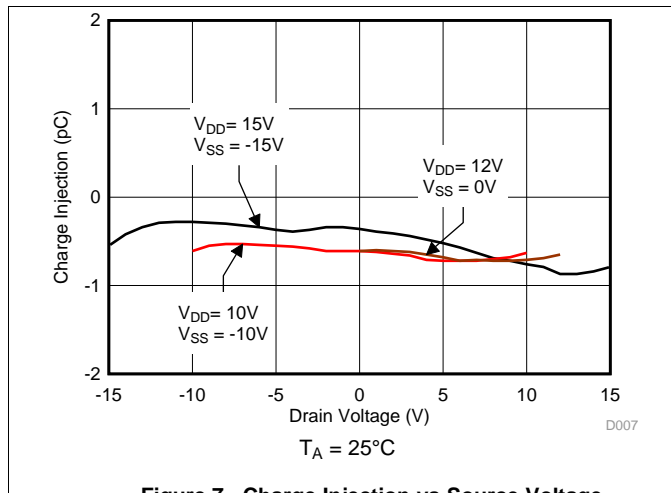

Figure 7. Charge Injection vs Source Voltage

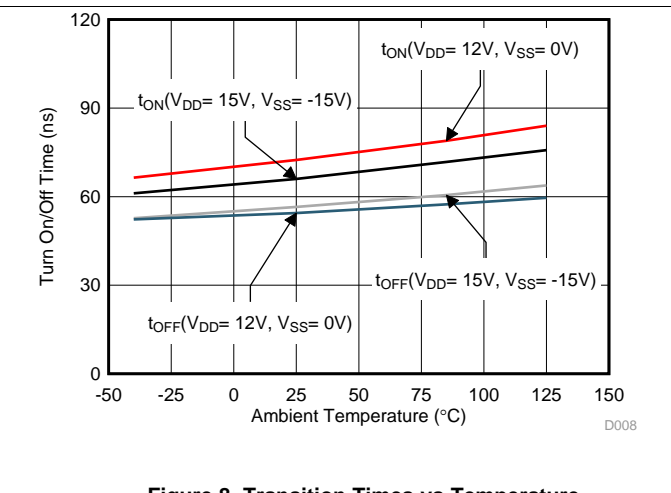

Figure 8. Transition Times vs Temperature

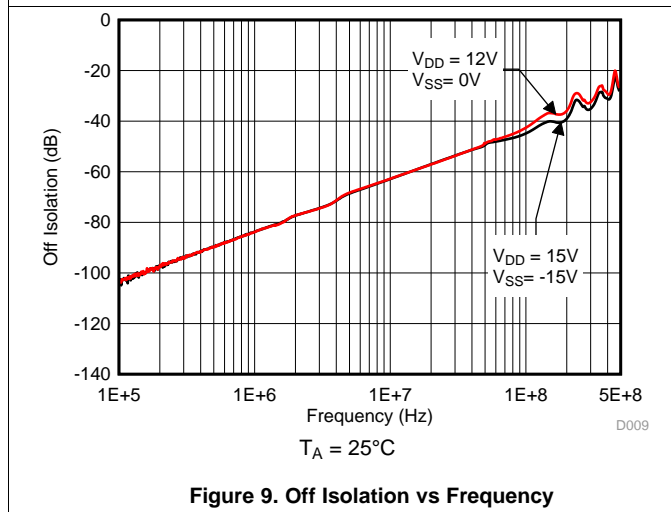

Figure 9. Off Isolation vs Frequency

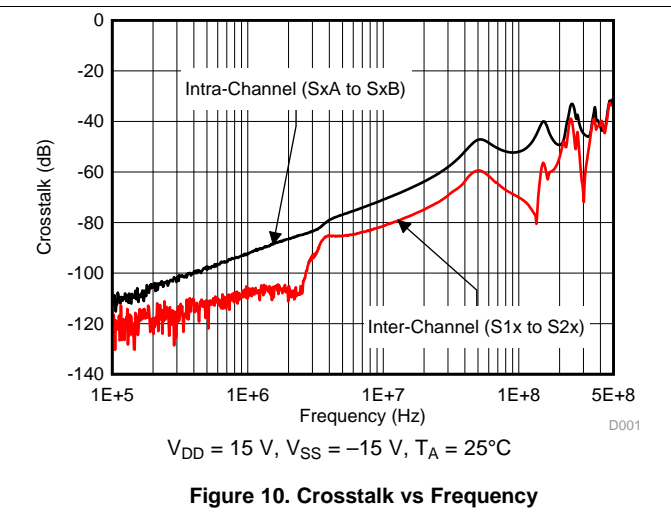

Figure 10. Crosstalk vs Frequency

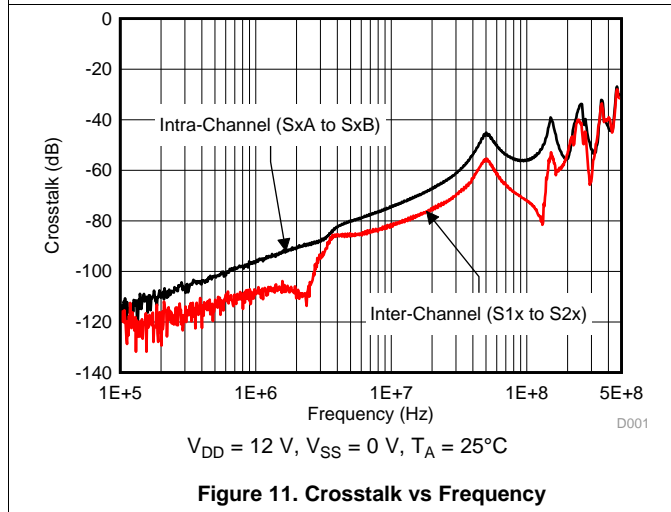

Figure 11. Crosstalk vs Frequency

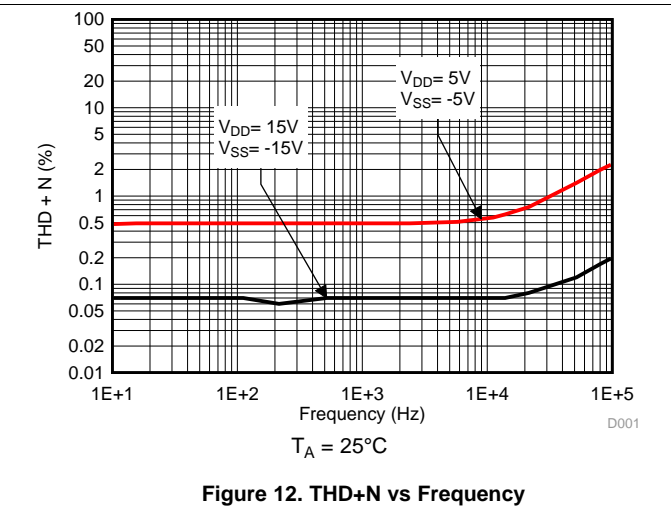

Figure 12. THD+N vs Frequency

Typical Characteristics (continued)

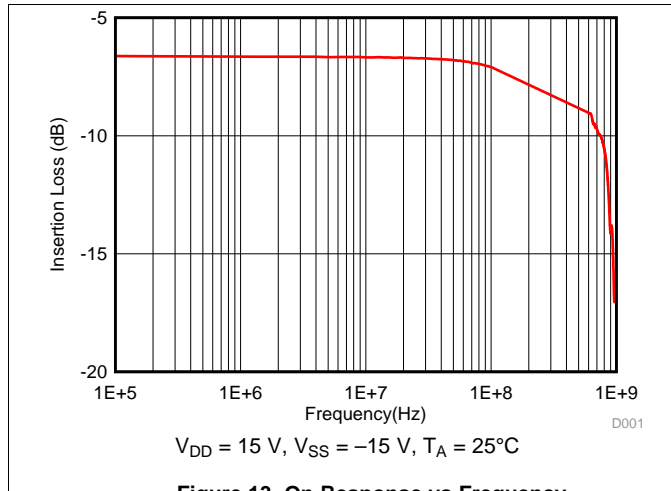

Figure 13. On Response vs Frequency

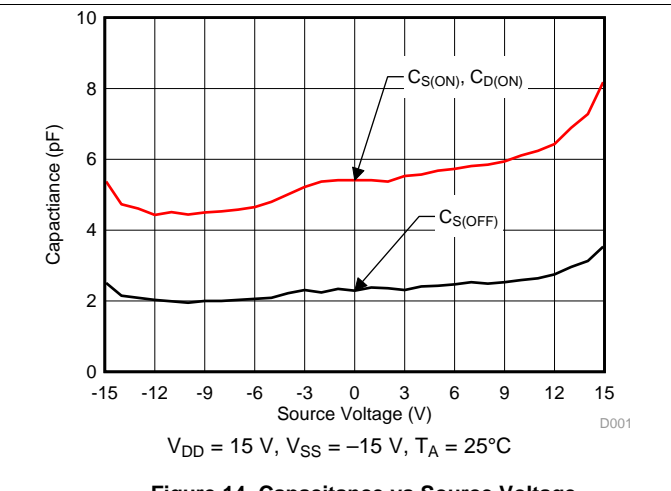

Figure 14. Capacitance vs Source Voltage

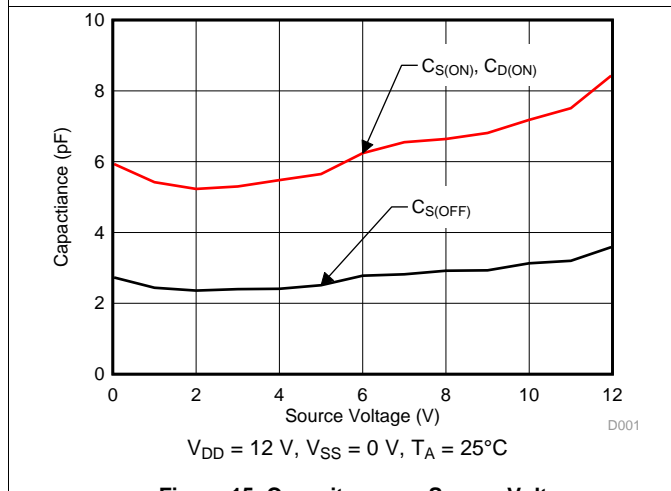

Figure 15. Capacitance vs Source Voltage

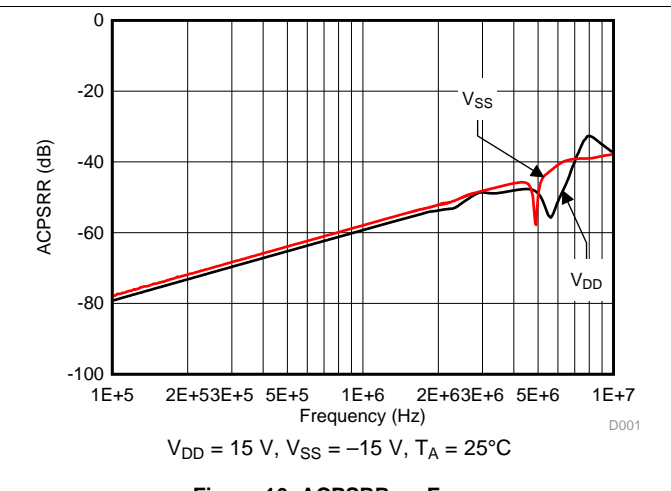

Figure 16. ACPSRR vs Frequency

## 7 Detailed Description

### 7.1 Overview

#### 7.1.1 On-Resistance

The on-resistance of the TMUX6136 is the ohmic resistance across the source (Sx) and drain (D) pins of the device. The on-resistance varies with input voltage and supply voltage. The symbol  $R_{ON}$  is used to denote on-resistance. The measurement setup used to measure  $R_{ON}$  is shown in Figure 17. Voltage (V) and current ( $I_{CH}$ ) are measured using this setup, and  $R_{ON}$  is computed as shown in Equation 1:

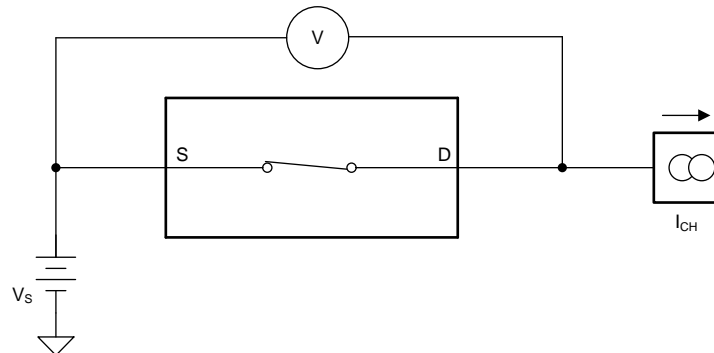

**Figure 17. On-Resistance Measurement Setup**

$$R_{ON} = V / I_{CH} \quad (1)$$

#### 7.1.2 Off-Leakage Current

Source off-leakage current is defined as the leakage current that flows into or out of the source pin when the switch is in the off state. This current is denoted by the symbol  $I_{S(OFF)}$ . Drain off-leakage measurement is not characterization since the drain pin is always connected to one of the two source pins.

The setup used to measure both off-leakage currents is shown in Figure 18

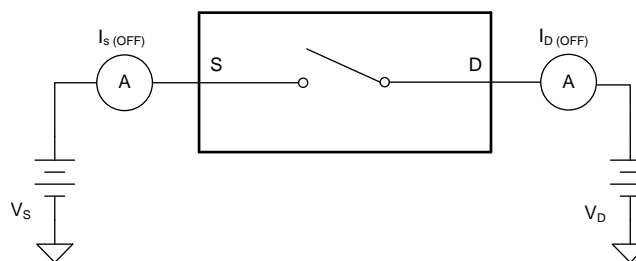

**Figure 18. Off-Leakage Measurement Setup**

## Overview (continued)

### 7.1.3 On-Leakage Current

On-leakage current is defined as the leakage current that flows into or out of the drain pin when the switch is in the on state. The source pin is left floating during the measurement. Figure 19 shows the circuit used for measuring the on-leakage current, denoted by  $I_{D(ON)}$ .

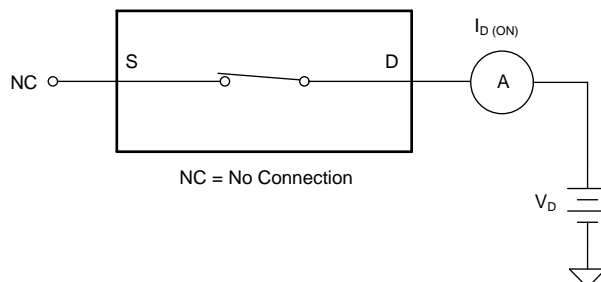

Figure 19. On-Leakage Measurement Setup

### 7.1.4 Transition Time

Transition time is defined as the time taken by the output of the TMUX6136 to rise or fall to 90% of the transition after the digital address signal has fallen or risen to 50% of the transition. Figure 20 shows the setup used to measure transition time, denoted by the symbol  $t_{TRAN}$ .

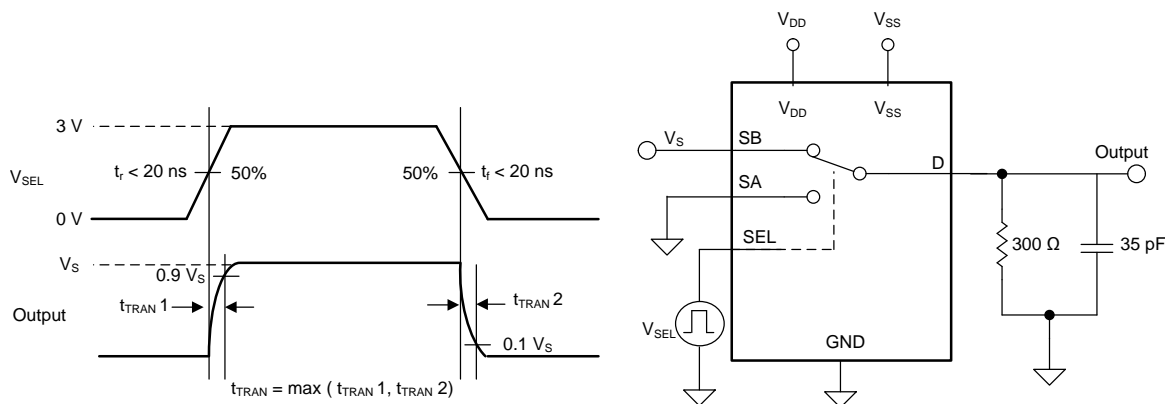

Figure 20. Transition-Time Measurement Setup

## Overview (continued)

### 7.1.5 Break-Before-Make Delay

Break-before-make delay is a safety feature that prevents two inputs from connecting when the TMUX6136 is switching. The TMUX6136 output first breaks from the on-state switch before making the connection with the next on-state switch. The time delay between the *break* and the *make* is known as break-before-make delay. Figure 21 shows the setup used to measure break-before-make delay, denoted by the symbol  $t_{BBM}$ .

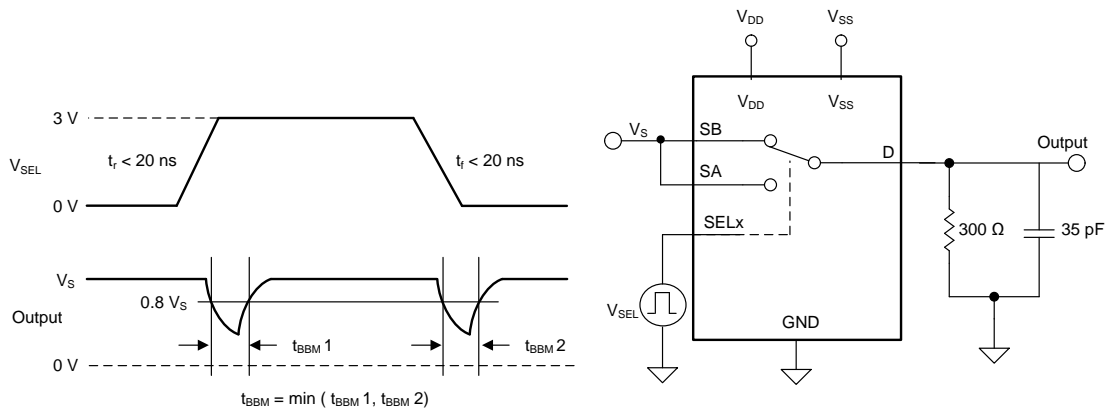

Figure 21. Break-Before-Make Delay Measurement Setup

### 7.1.6 Charge Injection

The TMUX6136 have a simple transmission-gate topology. Any mismatch in capacitance between the NMOS and PMOS transistors results in a charge injected into the drain or source during the falling or rising edge of the gate signal. The amount of charge injected into the source of the device is known as charge injection, and is denoted by the symbol  $Q_{INJ}$ . Figure 22 shows the setup used to measure charge injection from drain (D) to source (Sx).

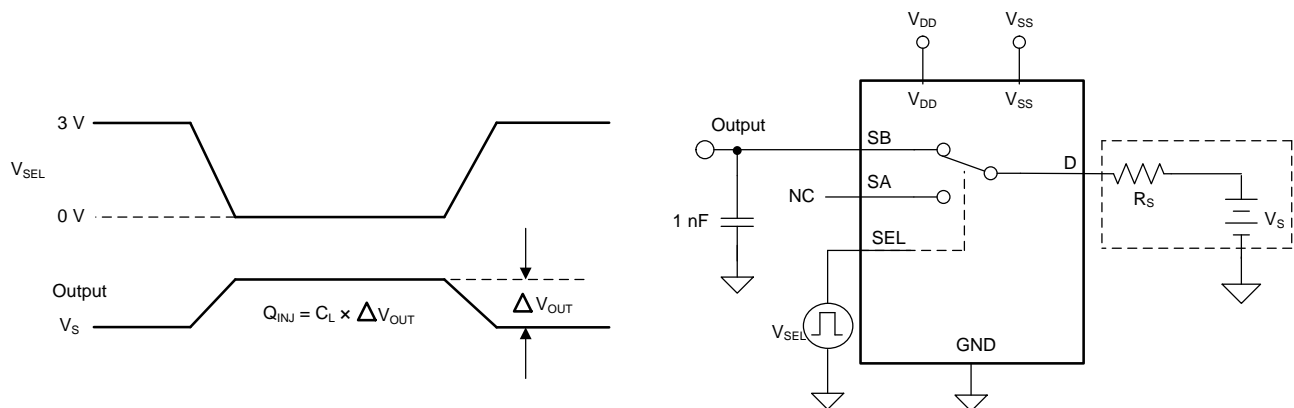

Figure 22. Charge-Injection Measurement Setup

### 7.1.7 Off Isolation

Off isolation is defined as the voltage at the drain pin (D) of the TMUX6136 when a  $1-V_{RMS}$  signal is applied to the source pin (Sx) of an off-channel. Figure 23 shows the setup used to measure off isolation. Use Equation 2 to compute off isolation.

Overview (continued)

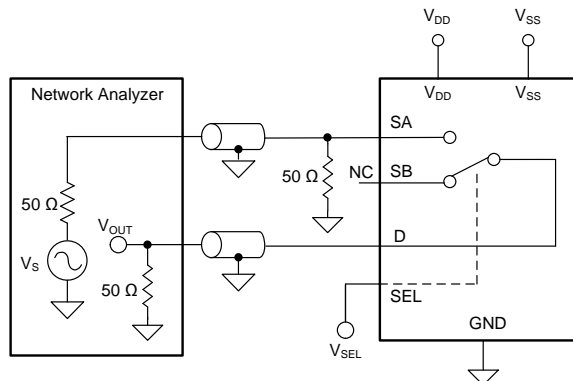

Figure 23. Off Isolation Measurement Setup

$$\text{Off Isolation} = 20 \cdot \text{Log} \left( \frac{V_{\text{OUT}}}{V_s} \right) \tag{2}$$

7.1.8 Channel-to-Channel Crosstalk

There are two types of crosstalk that can be defined for the TMUX6136:

1. Intra-channel crosstalk: the voltage at the source pin (Sx) of an off-switch input, when a 1-VRMS signal is applied at the source pin of an on-switch input in the same channel, as shown in Figure 24
2. Inter-channel crosstalk: the voltage at the source pin (Sx) of an on-switch input, when a 1-VRMS signal is applied at the source pin of an on-switch input in a different channel, as shown in Figure 25

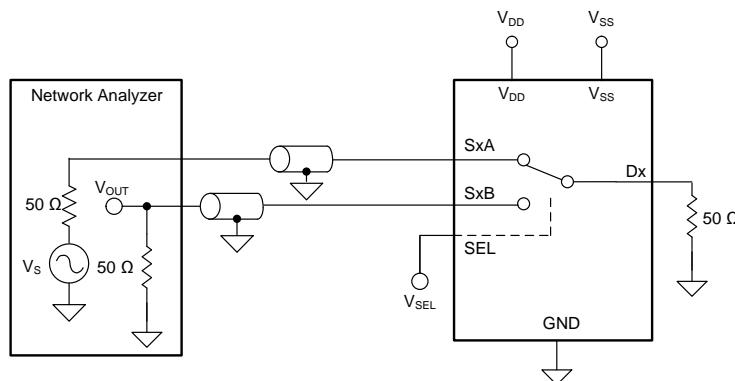
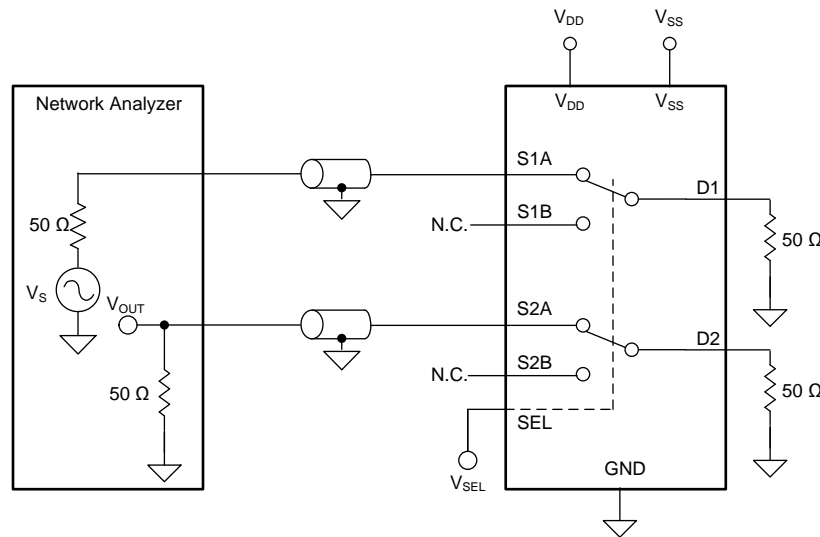

Figure 24. Intra-channel Crosstalk Measurement Setup

**Overview (continued)**

**Figure 25. Inter-channel Crosstalk Measurement Setup**

$$\text{Channel-to-Channel Crosstalk} = 20 \cdot \text{Log} \left( \frac{V_{\text{OUT}}}{V_{\text{S}}} \right) \quad (3)$$

**7.1.9 Bandwidth**

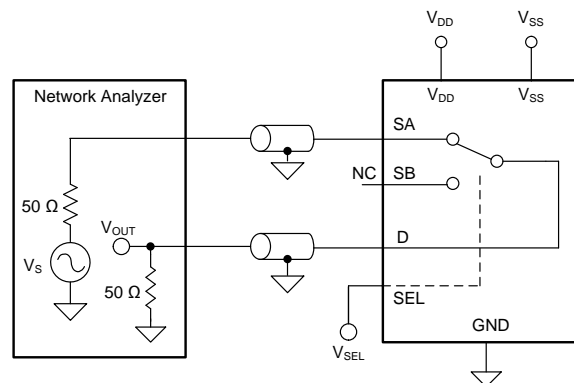
Bandwidth is defined as the range of frequencies that are attenuated by < 3 dB when the input is applied to the source pin (Sx) of an on-channel, and the output is measured at the drain pin (D) of the TMUX6136. Figure 26 shows the setup used to measure bandwidth of the mux. Use Equation 4 to compute the attenuation.

**Figure 26. Bandwidth Measurement Setup**

$$\text{Attenuation} = 20 \cdot \text{Log} \left( \frac{V_2}{V_1} \right) \quad (4)$$

**7.1.10 THD + Noise**

The total harmonic distortion (THD) of a signal is a measurement of the harmonic distortion, and is defined as the ratio of the sum of the powers of all harmonic components to the power of the fundamental frequency at the mux output. The on-resistance of the TMUX6136 varies with the amplitude of the input signal and results in distortion when the drain pin is connected to a low-impedance load. Total harmonic distortion plus noise is denoted as THD+N.

Overview (continued)

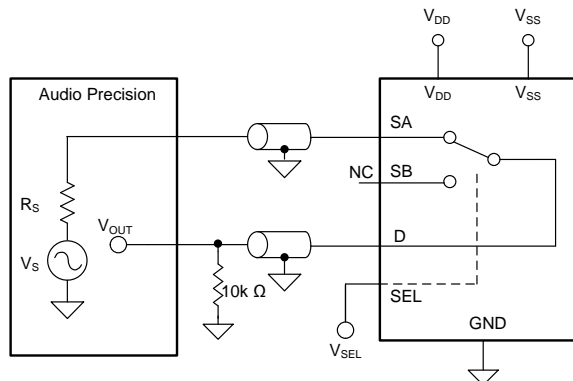

Figure 27. THD+N Measurement Setup

7.1.11 AC Power Supply Rejection Ratio (AC PSRR)

AC PSRR measures the ability of a device to prevent noise and spurious signals that appear on the supply voltage pin from coupling to the output of the switch. The DC voltage on the device supply is modulated by a sine wave of 620 mV<sub>PP</sub>. The ratio of the amplitude of signal on the output to the amplitude of the modulated signal is the AC PSRR.

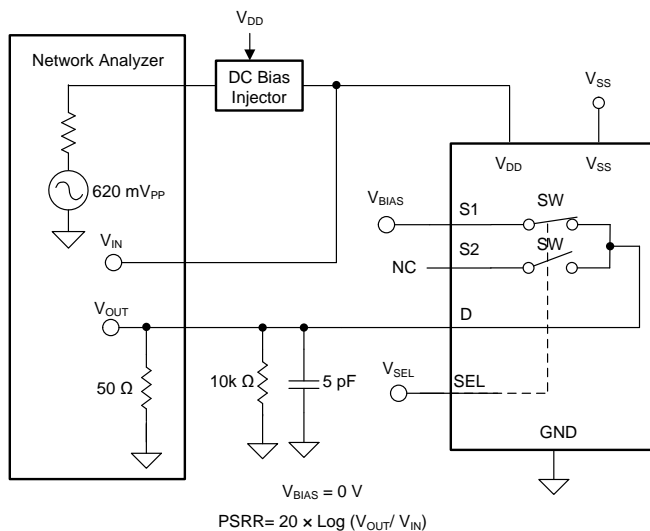
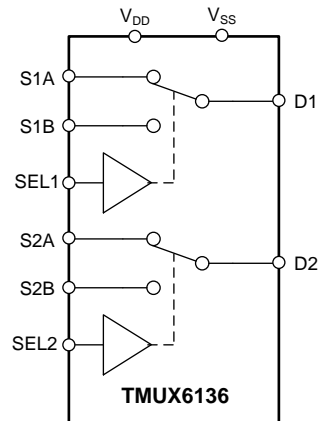

Figure 28. AC PSRR Measurement Setup

The [Functional Block Diagram](#) section provides a top-level block diagram of the TMUX6136. The TMUX6136 is a 4-channel, single-ended, analog multiplexer. Each channel is turned on or turned off based on the state of the address lines and enable pin.

## 7.2 Functional Block Diagram



Copyright © 2018, Texas Instruments Incorporated

## 7.3 Feature Description

### 7.3.1 Ultralow Leakage Current

The TMUX6136 provide extremely low on- and off-leakage currents. The TMUX6136 is capable of switching signals from high source-impedance inputs into a high input-impedance op amp with minimal offset error because of the ultralow leakage currents. Figure 29 shows typical leakage currents of the TMUX6136 versus temperature.

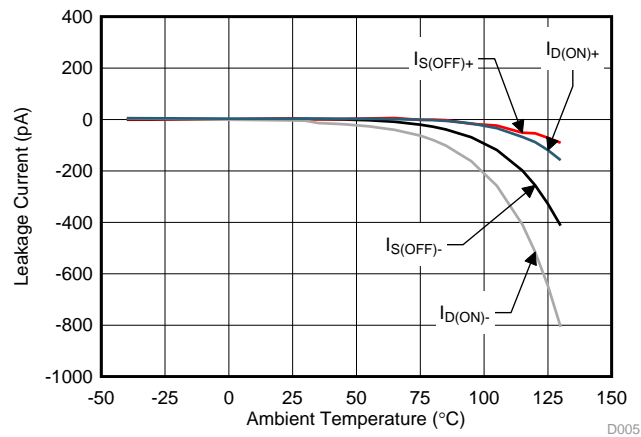

**Figure 29. Leakage Current vs Temperature**

### 7.3.2 Ultralow Charge Injection

The TMUX6136 is implemented with simple transmission gate topology, as shown in Figure 30. Any mismatch in the stray capacitance associated with the NMOS and PMOS causes an output level change whenever the switch is opened or closed.

## Feature Description (continued)

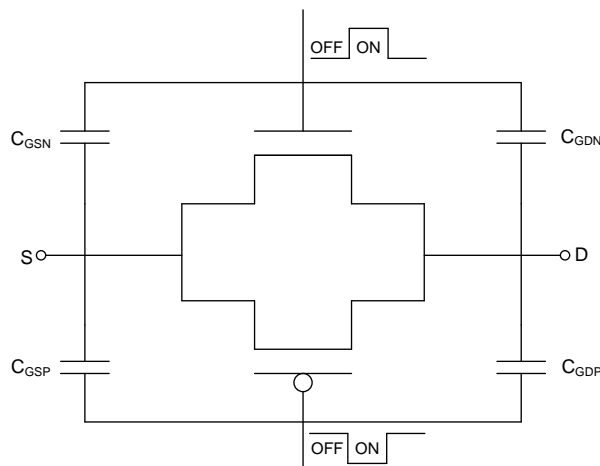

Figure 30. Transmission Gate Topology

The TMUX6136 utilizes special charge-injection cancellation circuitry that reduces the drain (D)-to-source (Sx) charge injection to as low as  $-0.4$  pC at  $V_S = 0$  V, as shown in Figure 31.

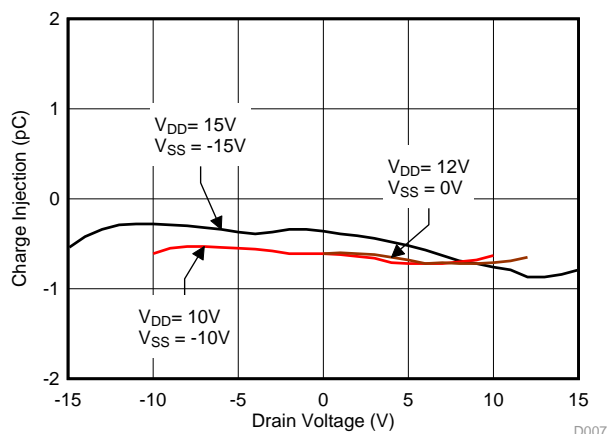

Figure 31. Charge Injection vs Drain Voltage

### 7.3.3 Bidirectional and Rail-to-Rail Operation

The TMUX6136 conducts equally well from source (Sx) to drain (D) or from drain (D) to source (Sx). Each TMUX6136 channel has very similar characteristics in both directions. The valid analog signal for TMUX6136 ranges from  $V_{SS}$  to  $V_{DD}$ . The input signal to the TMUX6136 swings from  $V_{SS}$  to  $V_{DD}$  without any significant degradation in performance.

## 7.4 Device Functional Modes

### 7.4.1 Truth Table

Table 1. TMUX6136 Truth Table

SELx	Switch A (S1A to D1 or S2A to D2)	Switch B (S1B to D1 or S2B to D2)
0	OFF	ON
1	ON	OFF

## 8 Application and Implementation

### NOTE

Information in the following applications sections is not part of the TI component specification, and TI does not warrant its accuracy or completeness. TI's customers are responsible for determining suitability of components for their purposes. Customers should validate and test their design implementation to confirm system functionality.

### 8.1 Application Information

The TMUX6136 offers outstanding input/output leakage currents and ultralow charge injection. The device operate up to 33 V ( $V_{DD}$  to  $V_{SS}$  dual supply) or 16.5 V ( $V_{DD}$  single supply), and offer true rail-to-rail input and output. The on-capacitance of the TMUX6136 is low. These features makes the TMUX6136 a precision, robust, high-performance analog multiplexer for high-voltage, industrial applications.

### 8.2 Typical Application

One example to take advantage of TMUX6136's precision performance is the implementation of parametric measurement unit (PMU) in the semiconductor automatic test equipment (ATE) application. The PMU is frequently used to characterize and measure the digital pin's DC characteristics of a device under test (DUT). Among all the PMU's capabilities, force voltage, measure current (FVMC), and force current, measure voltage (FCMV) are the two most typical configurations in DC characterizations.

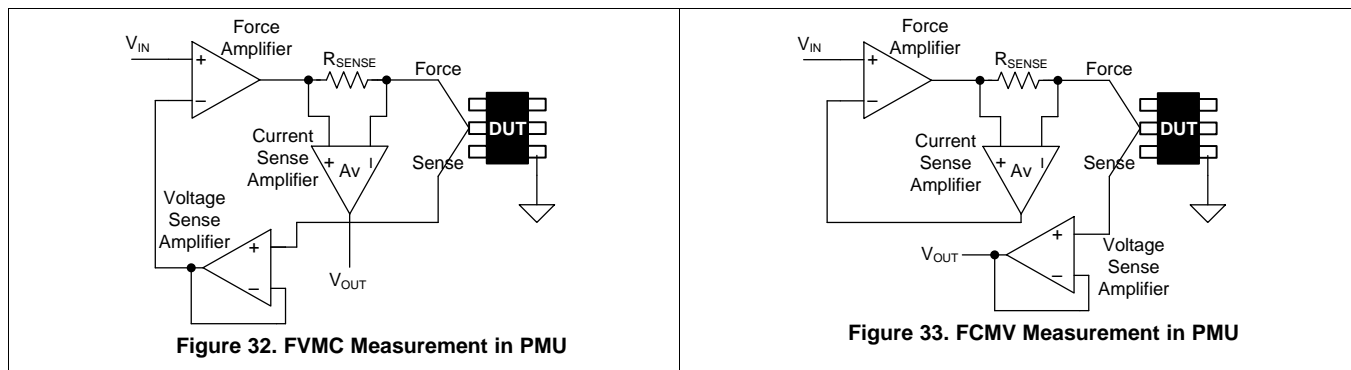

Figure 32 shows a simplified diagram of the PMU in FVMC configuration. The control loop consists of the force amplifier with the voltage sense amplifier (unity gain in this example) making up the feedback path. Current flowing through the DUT is measured by sensing the current flowing through a sense resistor ( $R_{SENSE}$ ) in series with the DUT. The current sense amplifier with a gain of  $A_v$  generates a voltage ( $V_{OUT}$ ) at its output and the voltage can then be measured by an ADC. The voltage produced at the DUT pin stays at the input voltage level ( $V_{IN}$ ) as long as the force amplifier doesn't rail out (ie.  $I_{DUT} \times R_{SENSE} \times A_v$  stays within the input voltage range of the force amplifier). Depending on level of the DUT current to be measured, different gain settings need to be configured for the current sense amplifier.

Figure 33 shows a simplified diagram of the PMU in FCMV mode. The voltage  $V_{IN}$  is now converted to a current through the following relationship:

$$\text{Force Current} = V_{IN} / (R_{SENSE} \times A_v) \tag{5}$$

The control loop consists of the force amplifier with the current sense amplifier making up the feedback path. The voltage at the DUT is sensed across the voltage sense amplifier (unity gain in this example) and presented at the output for sample.

## Typical Application (continued)

### 8.2.1 Design Requirements

The goal of this design example is to simplify the FVMC and FCMV functions of a PMU design using a SPDT switch. The FVMC configuration is useful to test a device being used as a power supply, or in continuity or leakage testing. In this configuration, the input voltage is directly applied to the DUT pin, and the current into/ out of the DUT pin is converted to a voltage by a sense resistor and measured by an analog to digital converter (ADC). In the FCMV mode, an input current is forced to the DUT and the produced voltage on the DUT pin is directly measured. In this example, the PMU design is required to meet the following specifications:

- Force voltage range:  $-15$  volts to  $+15$  volts
- Force current range:  $\pm 5$   $\mu$ A to  $\pm 50$  mA
- Measure voltage range:  $-15$  volts to  $+15$  volts
- Measure current range:  $\pm 5$   $\mu$ A to  $\pm 50$  mA

In addition to the voltage and current requirements, fast throughput is also a key requirements in ATE because it relates directly to the cost of manufacturing the DUT.

### 8.2.2 Detailed Design Procedure

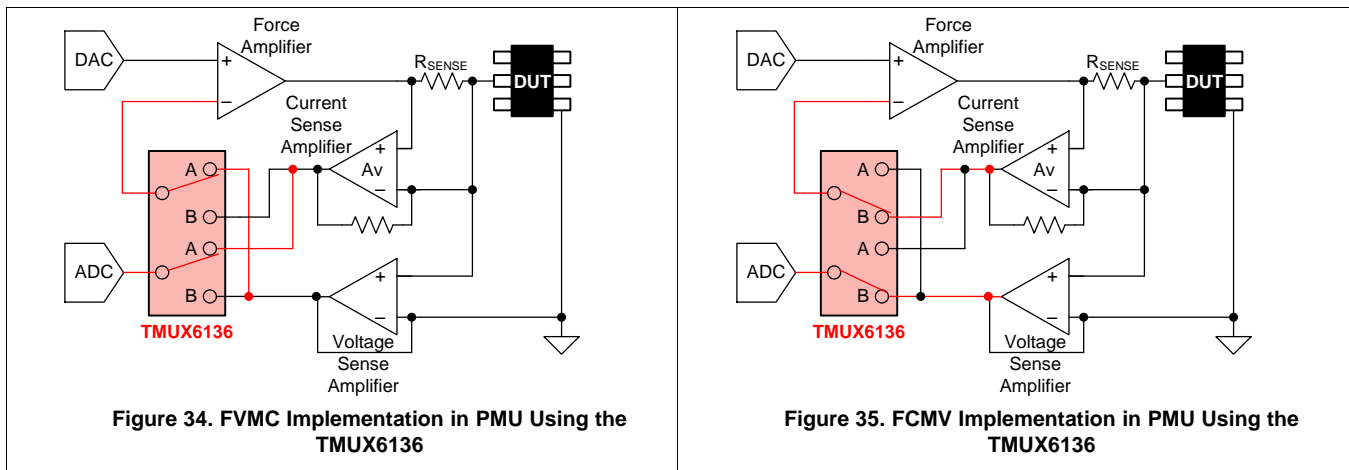

The FVMC and FCMV modes implementations can be combined with the use of a dual SPDT switch such as the TMUX6136. Figure 34 and Figure 35 shows simplified diagrams of such implementations. In the FVMC mode, the switch is toggled to position A and this allows the voltage sense amplifier to become part of the feedback loop and the voltage output of the current sense amplifier to be sampled by the ADC. In the FCMV mode, the switch is toggled to position B, and this allows the current sense amplifier to become part of the feedback loop and the voltage output of the voltage sense amplifier to be sampled by the ADC.

## Typical Application (continued)

### 8.2.3 Application Curve

The fast transition time of the TMUX6136 and low input/ output parasitic capacitance help minimize the settling time, making the TMUX6136 an excellent candidate to implement the FVMC and FCMV functions of the PMU. [Figure 36](#) shows the plot for the transition time vs. temperature for the TMUX6136.

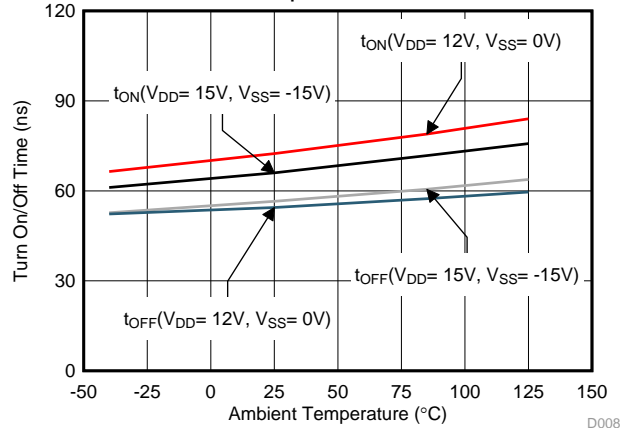

**Figure 36. Transition Time VS Temperature for TMUX6136**

## 9 Power Supply Recommendations

The TMUX6136 operates across a wide supply range of  $\pm 5$  V to  $\pm 16.5$  V (10 V to 16.5 V in single-supply mode). The device also perform well with unsymmetric supplies such as  $V_{DD} = 12$  V and  $V_{SS} = -5$  V. For reliable operation, use a supply decoupling capacitor ranging between 0.1  $\mu$ F to 10  $\mu$ F at both the  $V_{DD}$  and  $V_{SS}$  pins to ground.

## 10 Layout

### 10.1 Layout Guidelines

Figure 37 illustrates an example of a PCB layout with the TMUX6136.

Some key considerations are:

1. Decouple the  $V_{DD}$  and  $V_{SS}$  pins with a 0.1- $\mu\text{F}$  capacitor, placed as close to the pin as possible. Make sure that the capacitor voltage rating is sufficient for the  $V_{DD}$  and  $V_{SS}$  supplies.
2. Keep the input lines as short as possible.
3. Use a solid ground plane to help distribute heat and reduce electromagnetic interference (EMI) noise pickup.
4. Do not run sensitive analog traces in parallel with digital traces. Avoid crossing digital and analog traces if possible, and only make perpendicular crossings when necessary.

### 10.2 Layout Example

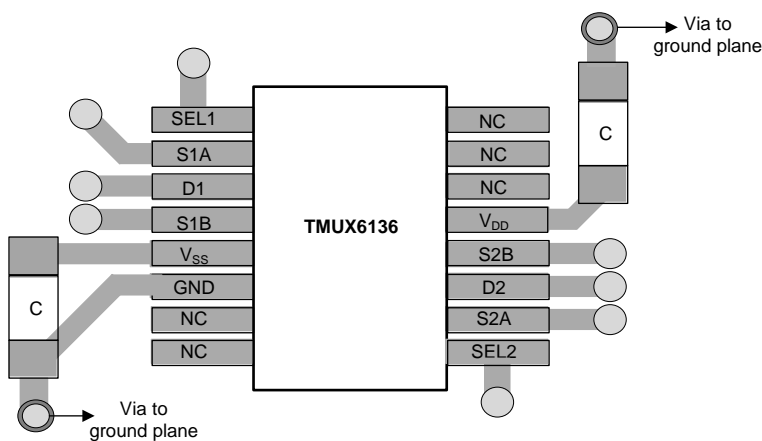

**Figure 37. TMUX6136 Layout Example**

## 11 Device and Documentation Support

### 11.1 Documentation Support

#### 11.1.1 Related Documentation

- [ADS8664 12-Bit, 500-kSPS, 4- and 8-Channel, Single-Supply, SAR ADCs with Bipolar Input Ranges \(SBAS492\)](#)
- [OPA192 36-V, Precision, Rail-to-Rail Input/Output, Low Offset Voltage, Low Input Bias Current Op Amp with e-Trim™ \(SBOS620\)](#)

### 11.2 Receiving Notification of Documentation Updates

To receive notification of documentation updates, navigate to the device product folder on ti.com. In the upper right corner, click on *Alert me* to register and receive a weekly digest of any product information that has changed. For change details, review the revision history included in any revised document.

### 11.3 Community Resources

The following links connect to TI community resources. Linked contents are provided "AS IS" by the respective contributors. They do not constitute TI specifications and do not necessarily reflect TI's views; see TI's [Terms of Use](#).

**TI E2E™ Online Community** *TI's Engineer-to-Engineer (E2E) Community*. Created to foster collaboration among engineers. At e2e.ti.com, you can ask questions, share knowledge, explore ideas and help solve problems with fellow engineers.

**Design Support** *TI's Design Support* Quickly find helpful E2E forums along with design support tools and contact information for technical support.

### 11.4 Trademarks

E2E is a trademark of Texas Instruments.

### 11.5 Electrostatic Discharge Caution



This integrated circuit can be damaged by ESD. Texas Instruments recommends that all integrated circuits be handled with appropriate precautions. Failure to observe proper handling and installation procedures can cause damage.

ESD damage can range from subtle performance degradation to complete device failure. Precision integrated circuits may be more susceptible to damage because very small parametric changes could cause the device not to meet its published specifications.

### 11.6 Glossary

[SLYZ022](#) — *TI Glossary*.

This glossary lists and explains terms, acronyms, and definitions.

## 12 Mechanical, Packaging, and Orderable Information

The following pages include mechanical, packaging, and orderable information. This information is the most current data available for the designated devices. This data is subject to change without notice and revision of this document. For browser-based versions of this data sheet, refer to the left-hand navigation.

**PACKAGING INFORMATION**

Orderable Device	Status (1)	Package Type	Package Drawing	Pins	Package Qty	Eco Plan (2)	Lead finish/ Ball material (6)	MSL Peak Temp (3)	Op Temp (°C)	Device Marking (4/5)	Samples
TMUX6136PWR	ACTIVE	TSSOP	PW	16	2000	RoHS & Green	NIPDAU	Level-1-260C-UNLIM	-40 to 125	MUX6136	Samples

(1) The marketing status values are defined as follows:

**ACTIVE:** Product device recommended for new designs.

**LIFEBUY:** TI has announced that the device will be discontinued, and a lifetime-buy period is in effect.

**NRND:** Not recommended for new designs. Device is in production to support existing customers, but TI does not recommend using this part in a new design.

**PREVIEW:** Device has been announced but is not in production. Samples may or may not be available.

**OBSOLETE:** TI has discontinued the production of the device.

(2) **RoHS:** TI defines "RoHS" to mean semiconductor products that are compliant with the current EU RoHS requirements for all 10 RoHS substances, including the requirement that RoHS substance do not exceed 0.1% by weight in homogeneous materials. Where designed to be soldered at high temperatures, "RoHS" products are suitable for use in specified lead-free processes. TI may reference these types of products as "Pb-Free".

**RoHS Exempt:** TI defines "RoHS Exempt" to mean products that contain lead but are compliant with EU RoHS pursuant to a specific EU RoHS exemption.

**Green:** TI defines "Green" to mean the content of Chlorine (Cl) and Bromine (Br) based flame retardants meet JS709B low halogen requirements of <=1000ppm threshold. Antimony trioxide based flame retardants must also meet the <=1000ppm threshold requirement.

(3) MSL, Peak Temp. - The Moisture Sensitivity Level rating according to the JEDEC industry standard classifications, and peak solder temperature.

(4) There may be additional marking, which relates to the logo, the lot trace code information, or the environmental category on the device.

(5) Multiple Device Markings will be inside parentheses. Only one Device Marking contained in parentheses and separated by a "-" will appear on a device. If a line is indented then it is a continuation of the previous line and the two combined represent the entire Device Marking for that device.

(6) Lead finish/Ball material - Orderable Devices may have multiple material finish options. Finish options are separated by a vertical ruled line. Lead finish/Ball material values may wrap to two lines if the finish value exceeds the maximum column width.

**Important Information and Disclaimer:** The information provided on this page represents TI's knowledge and belief as of the date that it is provided. TI bases its knowledge and belief on information provided by third parties, and makes no representation or warranty as to the accuracy of such information. Efforts are underway to better integrate information from third parties. TI has taken and continues to take reasonable steps to provide representative and accurate information but may not have conducted destructive testing or chemical analysis on incoming materials and chemicals. TI and TI suppliers consider certain information to be proprietary, and thus CAS numbers and other limited information may not be available for release.

In no event shall TI's liability arising out of such information exceed the total purchase price of the TI part(s) at issue in this document sold by TI to Customer on an annual basis.

## TAPE AND REEL INFORMATION



### QUADRANT ASSIGNMENTS FOR PIN 1 ORIENTATION IN TAPE



\*All dimensions are nominal

Device	Package Type	Package Drawing	Pins	SPQ	Reel Diameter (mm)	Reel Width W1 (mm)	A0 (mm)	B0 (mm)	K0 (mm)	P1 (mm)	W (mm)	Pin1 Quadrant
TMUX6136PWR	TSSOP	PW	16	2000	330.0	12.4	6.9	5.6	1.6	8.0	12.0	Q1

**TAPE AND REEL BOX DIMENSIONS**



\*All dimensions are nominal

Device	Package Type	Package Drawing	Pins	SPQ	Length (mm)	Width (mm)	Height (mm)
TMUX6136PWR	TSSOP	PW	16	2000	853.0	449.0	35.0



4220204/A 02/2017

NOTES:

1. All linear dimensions are in millimeters. Any dimensions in parenthesis are for reference only. Dimensioning and tolerancing per ASME Y14.5M.
2. This drawing is subject to change without notice.
3. This dimension does not include mold flash, protrusions, or gate burrs. Mold flash, protrusions, or gate burrs shall not exceed 0.15 mm per side.
4. This dimension does not include interlead flash. Interlead flash shall not exceed 0.25 mm per side.
5. Reference JEDEC registration MO-153.

# EXAMPLE BOARD LAYOUT

PW0016A

TSSOP - 1.2 mm max height

SMALL OUTLINE PACKAGE



LAND PATTERN EXAMPLE  
EXPOSED METAL SHOWN  
SCALE: 10X



SOLDER MASK DETAILS

4220204/A 02/2017

NOTES: (continued)

- 6. Publication IPC-7351 may have alternate designs.
- 7. Solder mask tolerances between and around signal pads can vary based on board fabrication site.

# EXAMPLE STENCIL DESIGN

PW0016A

TSSOP - 1.2 mm max height

SMALL OUTLINE PACKAGE



SOLDER PASTE EXAMPLE  
BASED ON 0.125 mm THICK STENCIL  
SCALE: 10X

4220204/A 02/2017

NOTES: (continued)

8. Laser cutting apertures with trapezoidal walls and rounded corners may offer better paste release. IPC-7525 may have alternate design recommendations.
9. Board assembly site may have different recommendations for stencil design.

## IMPORTANT NOTICE AND DISCLAIMER

TI PROVIDES TECHNICAL AND RELIABILITY DATA (INCLUDING DATASHEETS), DESIGN RESOURCES (INCLUDING REFERENCE DESIGNS), APPLICATION OR OTHER DESIGN ADVICE, WEB TOOLS, SAFETY INFORMATION, AND OTHER RESOURCES "AS IS" AND WITH ALL FAULTS, AND DISCLAIMS ALL WARRANTIES, EXPRESS AND IMPLIED, INCLUDING WITHOUT LIMITATION ANY IMPLIED WARRANTIES OF MERCHANTABILITY, FITNESS FOR A PARTICULAR PURPOSE OR NON-INFRINGEMENT OF THIRD PARTY INTELLECTUAL PROPERTY RIGHTS.

These resources are intended for skilled developers designing with TI products. You are solely responsible for (1) selecting the appropriate TI products for your application, (2) designing, validating and testing your application, and (3) ensuring your application meets applicable standards, and any other safety, security, or other requirements. These resources are subject to change without notice. TI grants you permission to use these resources only for development of an application that uses the TI products described in the resource. Other reproduction and display of these resources is prohibited. No license is granted to any other TI intellectual property right or to any third party intellectual property right. TI disclaims responsibility for, and you will fully indemnify TI and its representatives against, any claims, damages, costs, losses, and liabilities arising out of your use of these resources.

TI's products are provided subject to TI's Terms of Sale ([www.ti.com/legal/termsofsale.html](http://www.ti.com/legal/termsofsale.html)) or other applicable terms available either on [ti.com](http://ti.com) or provided in conjunction with such TI products. TI's provision of these resources does not expand or otherwise alter TI's applicable warranties or warranty disclaimers for TI products.

Mailing Address: Texas Instruments, Post Office Box 655303, Dallas, Texas 75265  
Copyright © 2020, Texas Instruments Incorporated