

High Performance, Programmable LVDS SMD MEMS Oscillator



3.2 x 2.5 x 0.75mm;
5.0 x 3.2 x 0.75mm;
7.0 x 5.0 x 0.9mm

ASTMUPLD



RoHS/RoHS II compliant

Moisture Sensitivity Level (MSL) – 1

FEATURES:

- Industry Standard package sizes: 3.2 x 2.5 x 0.75mm, 5 x 3.2 x 0.75mm, 7.0 x 5.0 x 0.9mm
- Any frequency between 1MHz and 625MHz
- Supply Voltage options: 3.3V, 2.8V, 2.25V~3.63V
- Ultra-low RMS phase jitter: 0.6ps typ. (@156.25MHz, integration bandwidth: 12kHz to 20MHz)
- Frequency Stability options: ±10ppm, ±20ppm, ±25ppm, ±50ppm over -20 to +70°C and -40 to +85°C

APPLICATIONS:

- 10GB Ethernet, SONET, SATA, SAS, Fiber Channel, PCI Express
- Storage
- Servers
- Networking
- Telecom
- Instrumentation
- Harsh environment (vibration, shock-prone and humid)

STANDARD SPECIFICATIONS:

Parameters		Min	Typ	Max	Unit	Notes
Output Frequency Range (F)		1		625	MHz	See Note 1 for Frequencies not supported
Frequency Stability (F _{stab})		-10		+10	ppm	Inclusive of initial tolerance at 25°C, and variations over operating temperature, rated power supply voltage and load
		-20		+20		
		-25		+25		
		-50		+50		
Operating Temperature Range (T _{use})		-20		+70	°C	Option "E"
		-40		+85		Option "L"
Aging@25°C	1 st year	-2		+2	ppm	
	10 years	-5		+5		
Supply Voltage (V _{dd})		2.25	2.5	2.75	V	Option "25"
		2.97	3.3	3.63		Option "33"
		2.25	-	3.63		Option "Blank" (default)
Input High Voltage(V _{IH})		70%*V _{dd}			V	Pin 1
Input Low Voltage(V _{IL})				30%*V _{dd}	V	Pin 1
Input Pull-up Impedance (Z _{in})			100	250	kΩ	Pin 1, OE logic high or logic low, \overline{ST} logic high
		2			MΩ	Pin 1, \overline{ST} logic low
Startup Time (T _{start})			6	10	ms	Measured from the time V _{dd} reaches its rated minimum value
Resume Time (T _{resume})			6	10	ms	In standby mode. Measured from the time \overline{ST} pin crosses 50% threshold
Duty Cycle		45		55	%	
Output Type		LVDS				
Current Consumption (I _{dd})			47	55	mA	Excluding load termination current, V _{dd} =2.5V or 3.3V
OE Disable Current (I _{OD})				35	mA	OE=Low
Output Disable Leakage Current (I _{leak})				1	μA	OE=Low
Standby Current (I _{std})				100	μA	\overline{ST} =Low, for all V _{dd}

Note: 1. Frequencies not supported:

Range 1: From 209.000001MHz to 210.999999MHz

Range 2: From 251.000001MHz to 263.999999MHz

Range 3: From 314.000001MHz to 422.999999MHz

Range 4: From 502.000001MHz to 527.999999MHz



5101 Hidden Creek Lane Spicewood TX 78669
Phone: 512-371-6159 | Fax: 512-351-8858
Terms and Conditions of Sale visit: Visit www.abracon.com

REVISED: 12/14/2018

ABRACON IS
ISO9001:2015
CERTIFIED

High Performance, Programmable LVDS SMD MEMS Oscillator



3.2 x 2.5 x 0.75mm;
5.0 x 3.2 x 0.75mm;
7.0 x 5.0 x 0.9mm

ASTMUPLD



RoHS/RoHS II compliant

(Continued)

Parameters	Min	Typ	Max	Unit	Notes
Differential Output Voltage (V_{OD})	250	350	450	mV	
V_{OD} Magnitude Change (ΔV_{OD})			50	mV	
Offset Voltage (V_{OS})	1.125	1.2	1.375	V	
V_{OS} Magnitude Change (ΔV_{OS})			50	mV	
Rise/Fall Time (T_r/T_f)		495	700	ps	20%-80%, Freq. = 1MHz~220MHz
		495	600		20%-80%, Freq. = 220MHz~625MHz
OE Enable/Disable Time (T_{oe})			115	ns	F=212.5MHz, 220MHz. For other frequencies, $T_{oe}=100ns+3*\text{cycles}$
RMS Period Jitter (T_{jitt})		1.2	1.7	ps	F=100MHz, 156.25MHz, 212.5MHz, 622.08MHz, $V_{dd}=2.5V$ or 3.3V
		1.4	1.7		F=266MHz, 312.5MHz, $V_{dd}=2.5V$ or 3.3V
RMS Phase Jitter (random) (T_{phj})		0.6	0.85	ps	F=156.25MHz, 312.5MHz, integration bandwidth=12kHz to 20MHz

Standard Frequencies

Standard Frequency (MHz)							
25.000000	50.000000	74.175824	74.250000	75.000000	98.304000	100.000000	106.250000
125.000000	133.000000	133.300000	133.330000	133.333000	133.333300	133.333330	133.333333
148.351648	148.500000	150.000000	155.520000	156.250000	161.132800	166.000000	166.600000
166.660000	166.666000	166.666600	166.666660	166.666666	200.000000	212.500000	

Absolute Maximum Ratings

Attempted operation outside the absolute maximum ratings may cause permanent damage to the part. Actual performance of the IC is only guaranteed within the operational specifications, not at absolute maximum ratings.

Parameters	Min.	Max.	Unit
Storage Temperature	-65	150	°C
V_{DD}	-0.5	4	V
Electrostatic Discharge (HBM)		2000	V
Soldering Temperature (follow standard Pb free soldering guidelines)		260	°C

Thermal Consideration

Package	θ_{JA} , 4 Layer Board (°C/W)	θ_{JC} , Bottom (°C/W)
7.0 x 5.0mm, 6-pin	142	27
5.0 x 3.2mm, 6-pin	97	20
3.2 x 2.5mm, 6-pin	109	20

High Performance, Programmable LVDS SMD MEMS Oscillator



3.2 x 2.5 x 0.75mm;
5.0 x 3.2 x 0.75mm;
7.0 x 5.0 x 0.9mm

ASTMUPLD

Pb RoHS/RoHS II compliant

PART IDENTIFICATION:

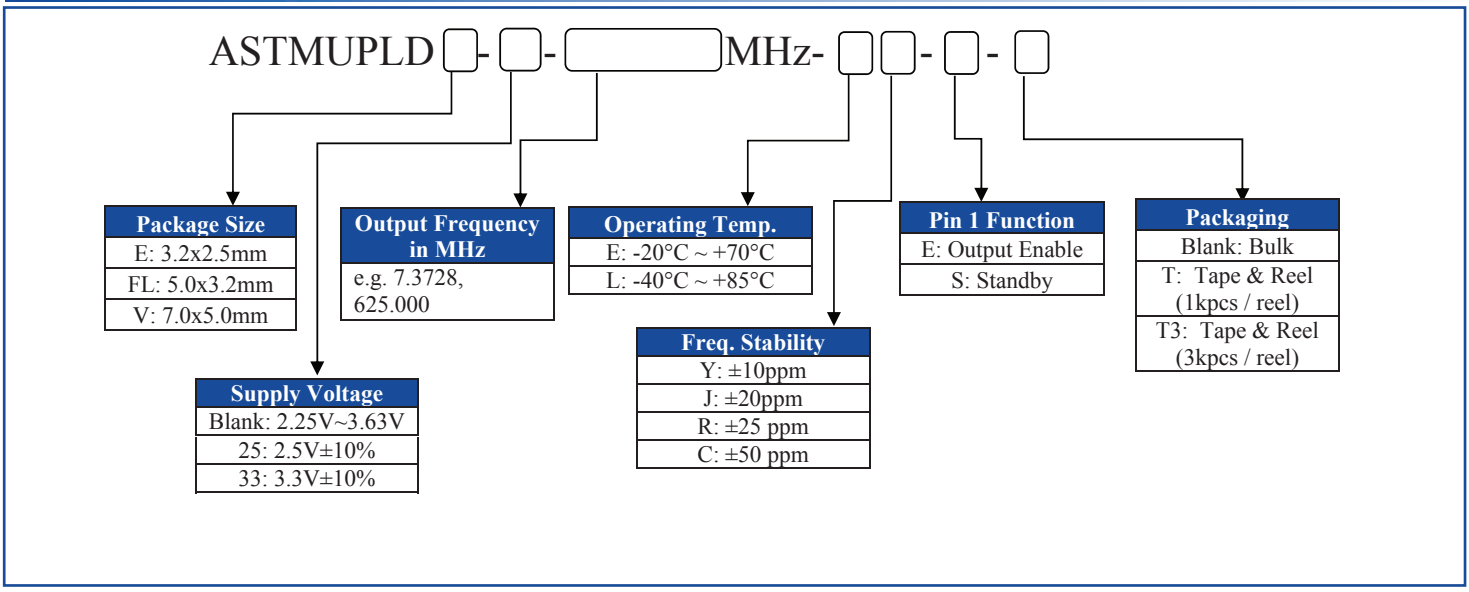

RECOMMENDED TERMINATION DIAGRAM

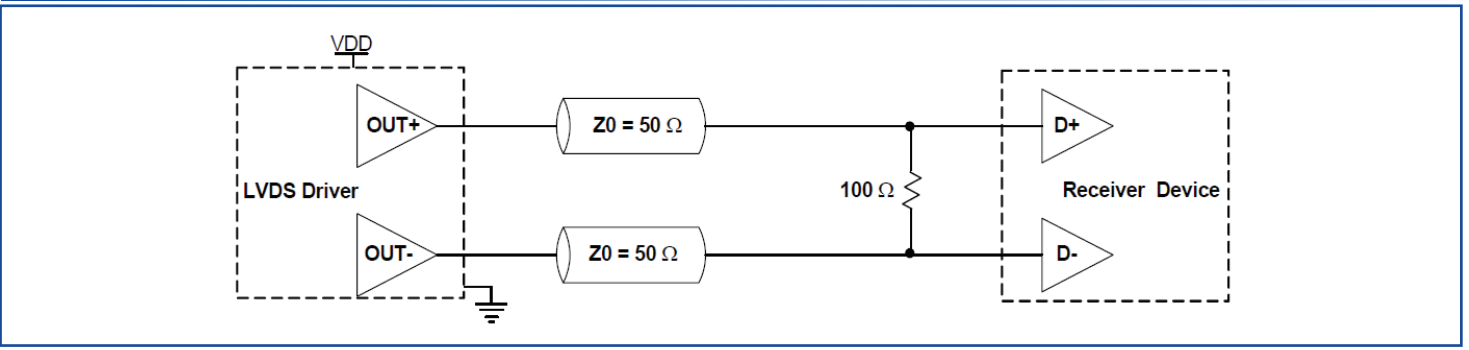

TYPICAL PHASE NOISE

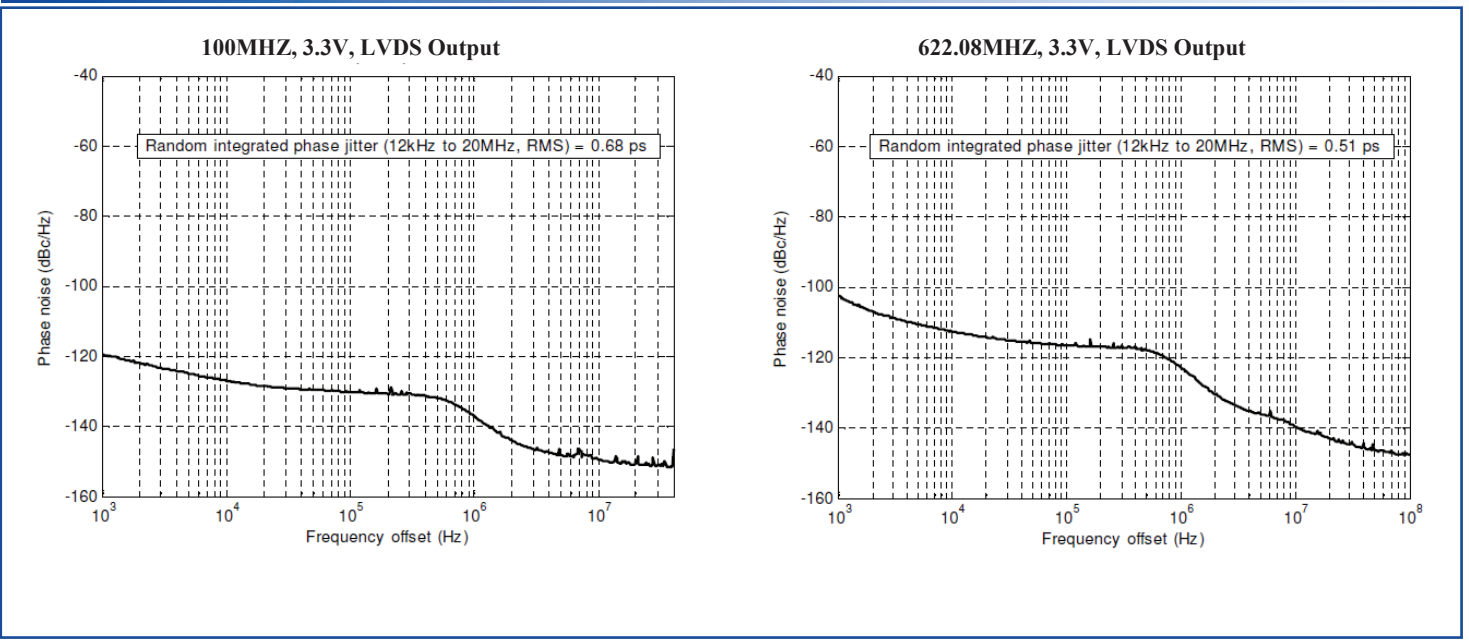

High Performance, Programmable LVDS SMD MEMS Oscillator



3.2 x 2.5 x 0.75mm;
5.0 x 3.2 x 0.75mm;
7.0 x 5.0 x 0.9mm

ASTMUPLD



RoHS/RoHS II compliant

OUTLINE DIMENSION:

3.2 x 2.5mm Package (Option "E")

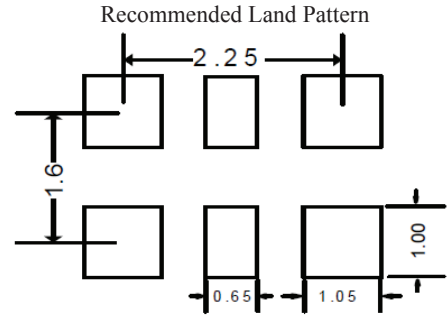
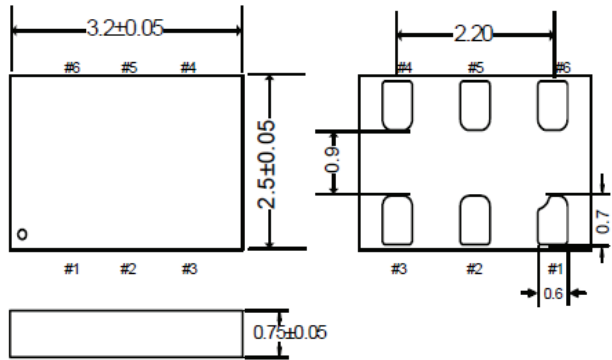

5.0 x 3.2mm Package (Option "FL")

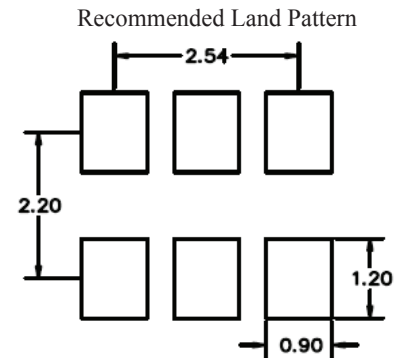
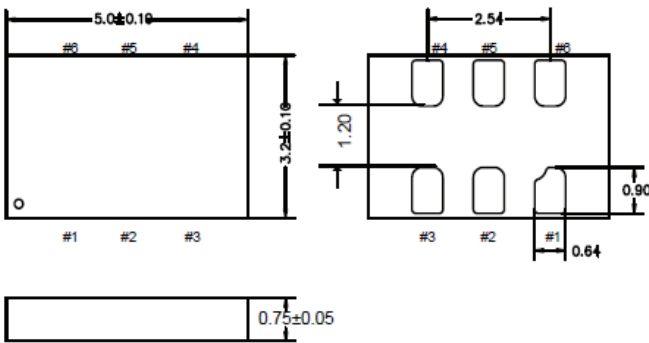

7.0 x 5.0mm Package (Option "V")

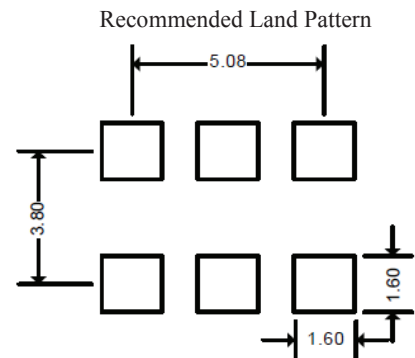
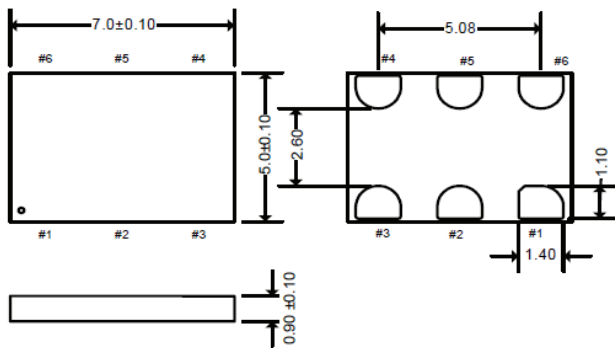

Dimensions: mm

Pin	Name		Functionality
1	OE/ $\overline{\text{ST}}$	Output Enable	H or Open: specified frequency output L: output is high impedance. Only output driver is disabled
		Standby	H or Open: specified frequency output L: output is low (weak pull down). Device goes to sleep mode. Supply current reduces to I_{std} .
2	NC	No Connect	Leave it floating or connect to GND for better heat dissipation
3	GND	Power	V_{dd} power supply ground ⁽¹⁾
4	Out+	Output	Oscillator output
5	Out-	Output	Complementary oscillator output
6	V_{dd}	Power	Power supply voltage ⁽¹⁾

Notes: 1. A capacitor value of 0.1 μ F between V_{dd} and GND is recommended.



3.2 x 2.5 x 0.75mm;
5.0 x 3.2 x 0.75mm;
7.0 x 5.0 x 0.9mm

ASTMUPLD



RoHS/RoHS II compliant

REFLOW PROFILE:

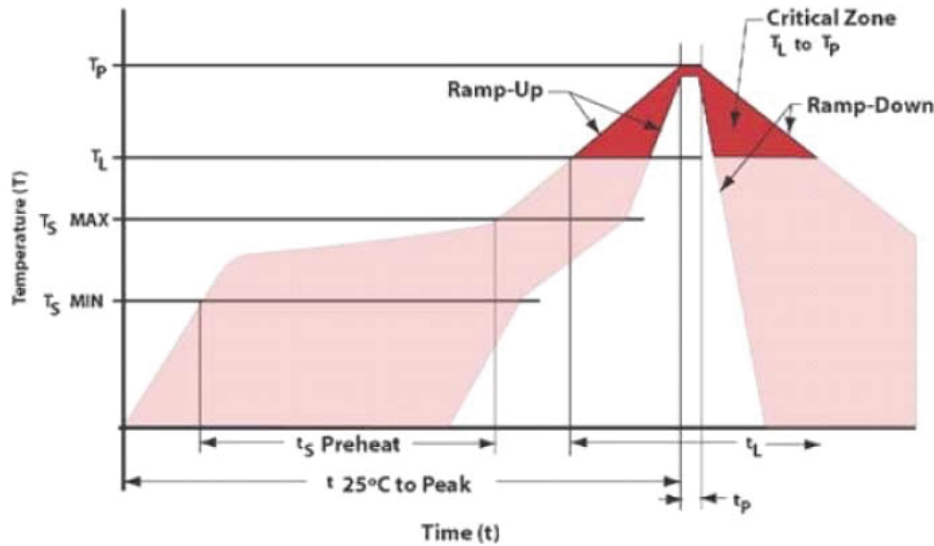

Item	Conditions
T _S MAX to T _L (Ramp-up Rate)	3°C/second max
Preheat	
Temperature Minimum (T _S MIN)	150°C
Temperature Typical (T _S TYP)	175°C
Temperature Maximum (T _S MAX)	200°C
Time (t _s)	60 – 180 seconds
Ramp-up Rate (T _L to T _P)	3°C/second max
Time Maintained Above	
Temperature (T _L)	217°C
Time (t _L)	60 – 150 seconds
Peak Temperature (T _P)	260°C max
Target Peak Temperature (T _P Target)	255°C
Time within 5°C of actual peak (t _p)	20 – 40 seconds
Max. Number of Reflow Cycles	3
Ramp-down Rate	6°C/second max
Time 25°C to Peak Temperature (t)	8 minutes max

High Performance, Programmable LVDS SMD MEMS Oscillator



3.2 x 2.5 x 0.75mm;
5.0 x 3.2 x 0.75mm;
7.0 x 5.0 x 0.9mm

ASTMUPLD

RoHS/RoHS II compliant

TAPE & REEL:

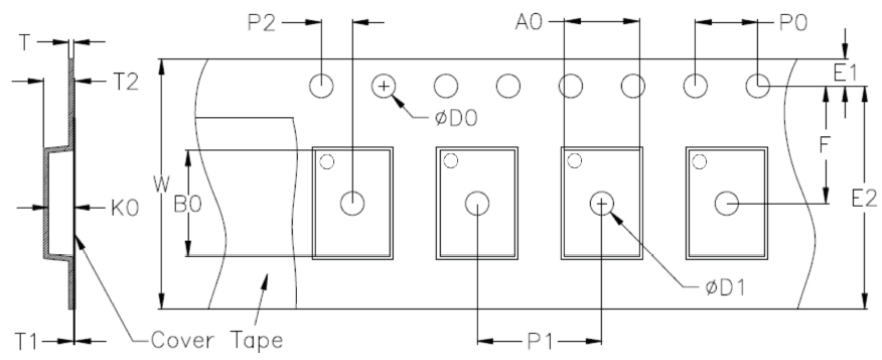

Unit: mm

Device Size	D0	D1 min.	E1	E2 min.	F	P0	P1	P2
3225	1.5+0.1/-0.0	1.5	1.75±0.1	10.25	5.5±0.05	4.0±0.1	4.0±0.1	2.0±0.05
5032	1.5+0.1/-0.0	1.5	1.75±0.1	10.25	5.5±0.05	4.0±0.1	8.0±0.1	2.0±0.05
7050	1.5+0.1/-0.0	1.5	1.75±0.1	14.25	7.5±0.1	4.0±0.1	8.0±0.1	2.0±0.1

Unit: mm

Device Size	T	T1 max.	T2 max.	W max.	A0	B0	K0
3225	0.6	0.1	1.65	12.3	2.8±0.10	3.5±0.10	1.10±0.10
5032	0.6	0.1	1.65	12.3	3.5±0.10	5.3±0.10	1.10±0.10
7050	0.6	0.1	1.80	16.3	5.4±0.10	7.4±0.10	1.3±0.10

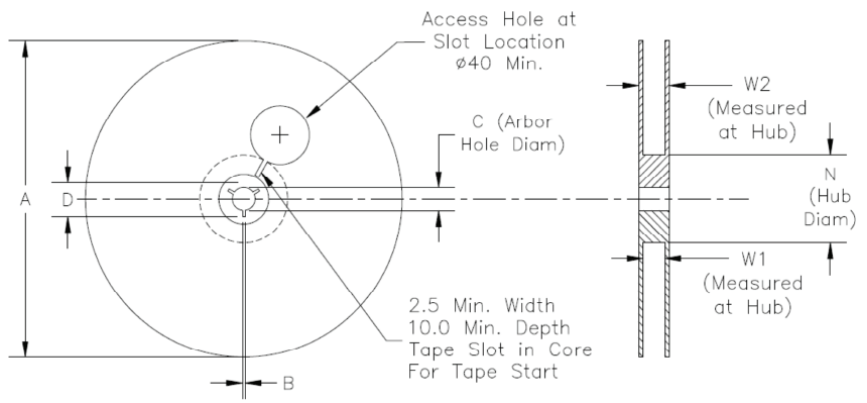

Unit: mm

Tape Size	A max.	B min.	C	D min.	N	W1	W2 max.
12mm	180	1.5	13.0±0.2	20.2	60±0.5	12.4+2.0/-0	18.4
	330	1.5	13.0±0.2	20.2	100±0.5	12.4+2.0/-0	18.4
16mm	180	1.5	13.0±0.2	20.2	60±0.5	16.4+2.0/-0	22.4
	330	1.5	13.0±0.2	20.2	100±0.5	16.4+2.0/-0	22.4

Device Size	"T" (1k/reel)		"T3" (3k/reel)	
3225	12mm Tape	7" Reel	12mm Tape	7" Reel
5032	12mm Tape	7" Reel	12mm Tape	13" Reel
7050	16mm Tape	7" Reel	16mm Tape	13" Reel

ATTENTION: Abracon LLC's products are COTS – Commercial-Off-The-Shelf products; suitable for Commercial, Industrial and, where designated, Automotive Applications. Abracon's products are not specifically designed for Military, Aviation, Aerospace, Life-dependent Medical applications or any application requiring high reliability where component failure could result in loss of life and/or property. For applications requiring high reliability and/or presenting an extreme operating environment, written consent and authorization from Abracon LLC is required. Please contact Abracon LLC for more information.



5101 Hidden Creek Lane Spicewood TX 78669
Phone: 512-371-6159 | Fax: 512-351-8858
Terms and Conditions of Sale visit: Visit www.abracon.com

REVISED: 12/14/2018

ABRACON IS
ISO9001:2015
CERTIFIED

Mouser Electronics

Authorized Distributor

Click to View Pricing, Inventory, Delivery & Lifecycle Information:

ABRACON:

[ASTMUPLDFL-500.000MHZ-LY-E-T3](#) [ASTMUPLDFL-500.000MHZ-LY-E-T](#) [ASTMUPLDE-500.000MHZ-LY-E-T](#)
[ASTMUPLDE-212.500MHZ-LY-E-T3](#) [ASTMUPLDFL-200.000MHZ-LY-E-T3](#) [ASTMUPLDV-212.500MHZ-LY-E-T3](#)
[ASTMUPLDE-156.250MHZ-LY-E-T](#) [ASTMUPLDE-312.500MHZ-LY-E](#) [ASTMUPLDFL-125.000MHZ-LY-E-T3](#)
[ASTMUPLDFL-125.000MHZ-LY-E](#) [ASTMUPLDFL-156.250MHZ-LY-E](#) [ASTMUPLDE-212.500MHZ-LY-E-T](#)
[ASTMUPLDE-100.000MHZ-LY-E-T](#) [ASTMUPLDV-100.000MHZ-LY-E-T](#) [ASTMUPLDFL-156.250MHZ-LY-E-T](#)
[ASTMUPLDV-500.000MHZ-LY-E](#) [ASTMUPLDE-312.500MHZ-LY-E-T](#) [ASTMUPLDE-500.000MHZ-LY-E-T3](#)
[ASTMUPLDV-125.000MHZ-LY-E-T3](#) [ASTMUPLDV-125.000MHZ-LY-E-T](#) [ASTMUPLDFL-200.000MHZ-LY-E](#)
[ASTMUPLDFL-212.500MHZ-LY-E](#) [ASTMUPLDE-156.250MHZ-LY-E](#) [ASTMUPLDV-156.250MHZ-LY-E-T3](#)
[ASTMUPLDFL-200.000MHZ-LY-E-T](#) [ASTMUPLDFL-100.000MHZ-LY-E-T](#) [ASTMUPLDFL-100.000MHZ-LY-E](#)
[ASTMUPLDV-200.000MHZ-LY-E](#) [ASTMUPLDE-100.000MHZ-LY-E](#) [ASTMUPLDE-200.000MHZ-LY-E](#) [ASTMUPLDV-](#)
[200.000MHZ-LY-E-T](#) [ASTMUPLDE-125.000MHZ-LY-E-T3](#) [ASTMUPLDV-312.500MHZ-LY-E](#) [ASTMUPLDV-](#)
[100.000MHZ-LY-E-T3](#) [ASTMUPLDV-500.000MHZ-LY-E-T](#) [ASTMUPLDV-312.500MHZ-LY-E-T](#) [ASTMUPLDFL-](#)
[212.500MHZ-LY-E-T](#) [ASTMUPLDFL-500.000MHZ-LY-E](#) [ASTMUPLDE-125.000MHZ-LY-E-T](#) [ASTMUPLDE-](#)
[125.000MHZ-LY-E](#) [ASTMUPLDFL-312.500MHZ-LY-E-T3](#) [ASTMUPLDE-312.500MHZ-LY-E-T3](#) [ASTMUPLDV-](#)
[500.000MHZ-LY-E-T3](#) [ASTMUPLDE-100.000MHZ-LY-E-T3](#) [ASTMUPLDV-212.500MHZ-LY-E](#) [ASTMUPLDFL-](#)
[312.500MHZ-LY-E](#) [ASTMUPLDFL-212.500MHZ-LY-E-T3](#) [ASTMUPLDV-100.000MHZ-LY-E](#) [ASTMUPLDE-](#)
[500.000MHZ-LY-E](#) [ASTMUPLDV-156.250MHZ-LY-E](#) [ASTMUPLDV-156.250MHZ-LY-E-T](#) [ASTMUPLDE-200.000MHZ-](#)
[LY-E-T](#) [ASTMUPLDFL-312.500MHZ-LY-E-T](#) [ASTMUPLDE-156.250MHZ-LY-E-T3](#) [ASTMUPLDV-125.000MHZ-LY-E](#)
[ASTMUPLDV-200.000MHZ-LY-E-T3](#) [ASTMUPLDE-200.000MHZ-LY-E-T3](#) [ASTMUPLDV-212.500MHZ-LY-E-T](#)
[ASTMUPLDV-312.500MHZ-LY-E-T3](#) [ASTMUPLDFL-125.000MHZ-LY-E-T](#) [ASTMUPLDFL-156.250MHZ-LY-E-T3](#)
[ASTMUPLDFL-100.000MHZ-LY-E-T3](#) [ASTMUPLDE-212.500MHZ-LY-E](#) [ASTMUPLDFL-500.000MHZ-LJ-E-T3](#)
[ASTMUPLDV-500.000MHZ-LJ-E-T](#) [ASTMUPLDE-100.000MHZ-LJ-E-T](#) [ASTMUPLDV-212.500MHZ-LJ-E-T3](#)
[ASTMUPLDFL-156.250MHZ-LJ-E-T](#) [ASTMUPLDE-312.500MHZ-LJ-E-T](#) [ASTMUPLDV-125.000MHZ-LJ-E-T](#)
[ASTMUPLDE-125.000MHZ-LJ-E](#) [ASTMUPLDFL-156.250MHZ-LJ-E](#) [ASTMUPLDV-125.000MHZ-LJ-E](#) [ASTMUPLDFL-](#)
[125.000MHZ-LJ-E-T3](#) [ASTMUPLDFL-100.000MHZ-LJ-E-T3](#) [ASTMUPLDV-125.000MHZ-LJ-E-T3](#) [ASTMUPLDE-](#)
[212.500MHZ-LJ-E](#) [ASTMUPLDE-212.500MHZ-LJ-E-T](#) [ASTMUPLDFL-312.500MHZ-LJ-E-T3](#) [ASTMUPLDFL-](#)
[125.000MHZ-LJ-E](#) [ASTMUPLDFL-125.000MHZ-LJ-E-T](#) [ASTMUPLDFL-500.000MHZ-LJ-E-T](#) [ASTMUPLDE-](#)
[156.250MHZ-LJ-E](#) [ASTMUPLDV-156.250MHZ-LJ-E-T3](#) [ASTMUPLDFL-212.500MHZ-LJ-E-T](#) [ASTMUPLDV-](#)
[212.500MHZ-LJ-E](#) [ASTMUPLDV-156.250MHZ-LJ-E-T](#) [ASTMUPLDFL-100.000MHZ-LJ-E-T](#) [ASTMUPLDV-](#)

[212.500MHZ-LJ-E-T](#) [ASTMUPLDV-200.000MHZ-LJ-E-T3](#) [ASTMUPLDV-500.000MHZ-LJ-E-T3](#) [ASTMUPLDE-](#)
[500.000MHZ-LJ-E-T](#) [ASTMUPLDE-200.000MHZ-LJ-E](#) [ASTMUPLDV-100.000MHZ-LJ-E-T3](#) [ASTMUPLDE-](#)
[312.500MHZ-LJ-E-T3](#) [ASTMUPLDFL-312.500MHZ-LJ-E-T](#) [ASTMUPLDFL-200.000MHZ-LJ-E-T](#) [ASTMUPLDFL-](#)
[212.500MHZ-LJ-E-T3](#) [ASTMUPLDFL-156.250MHZ-LJ-E-T3](#) [ASTMUPLDFL-100.000MHZ-LJ-E](#)